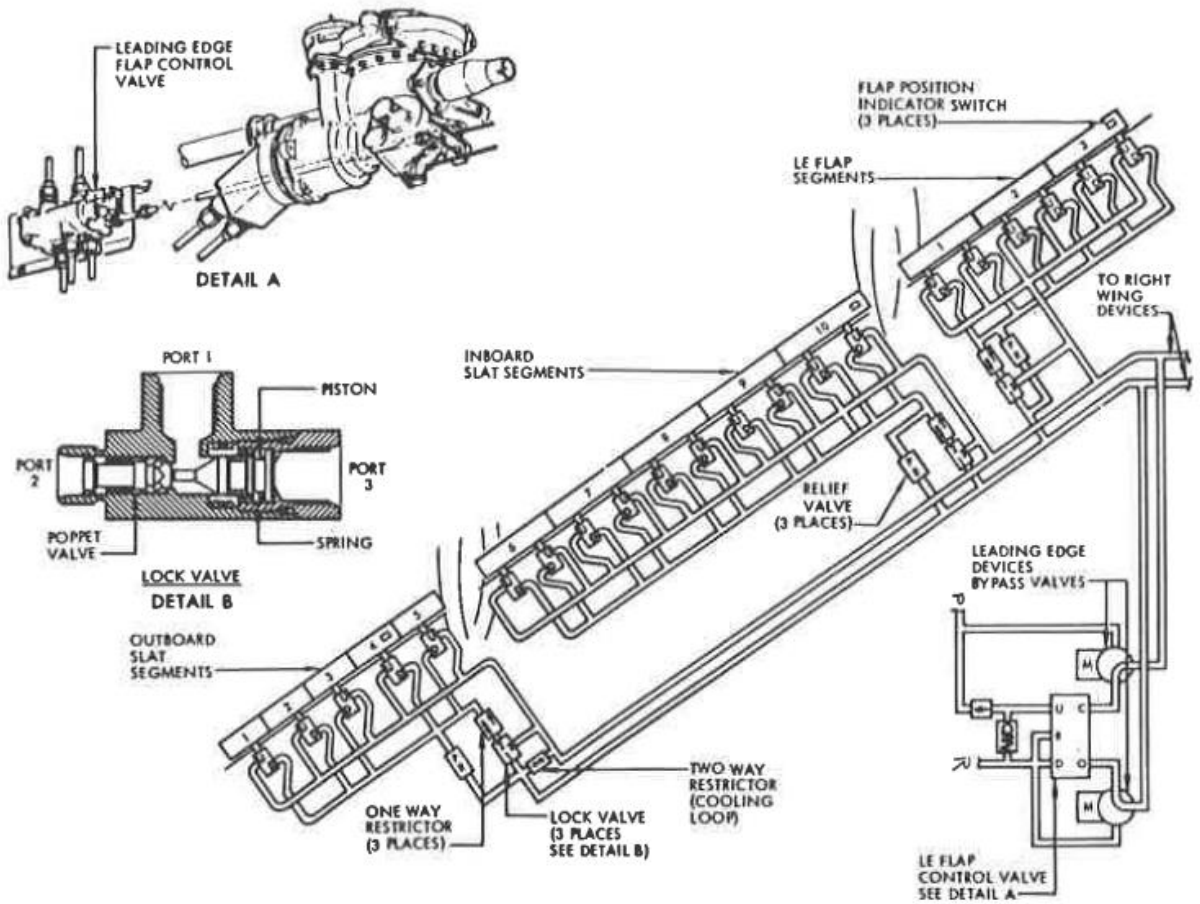


Boeing 707



Boeing 727

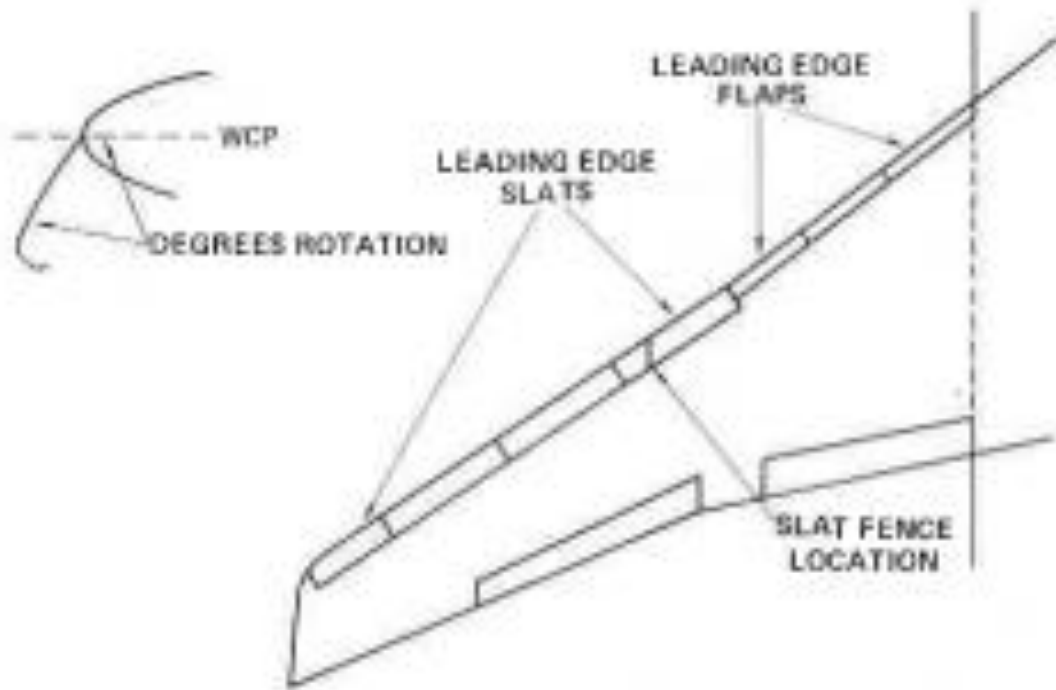
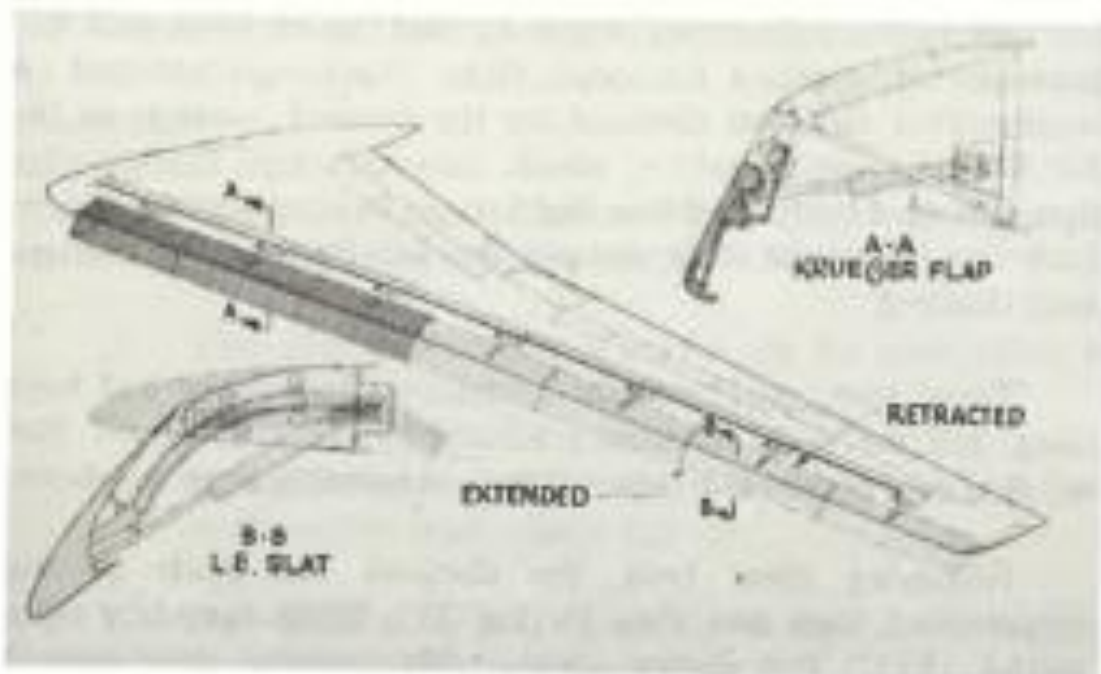
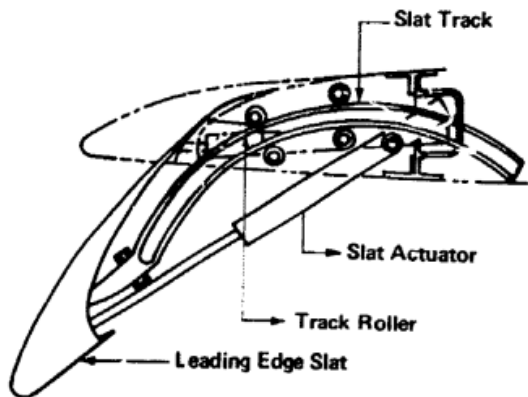
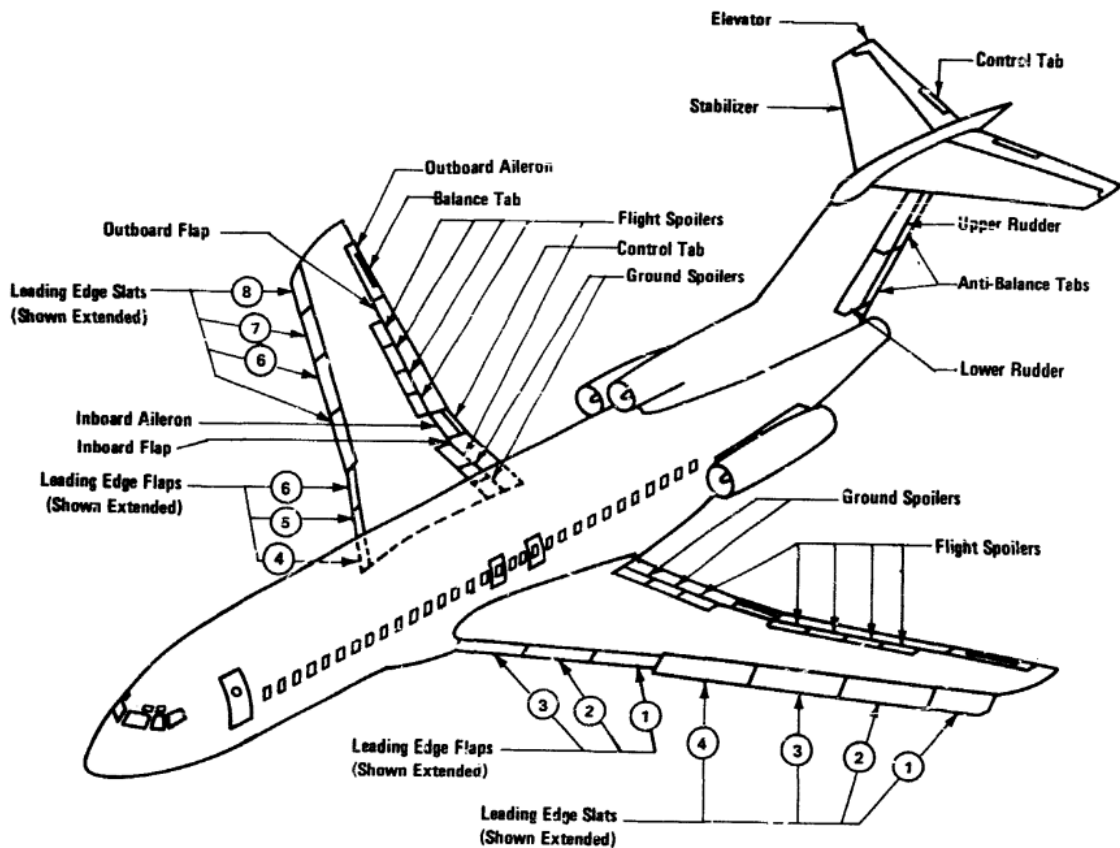
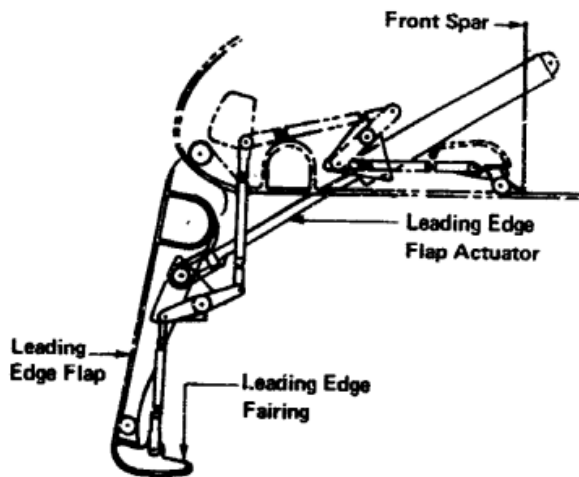


Figure 2- Wing Leading Edge Configuration





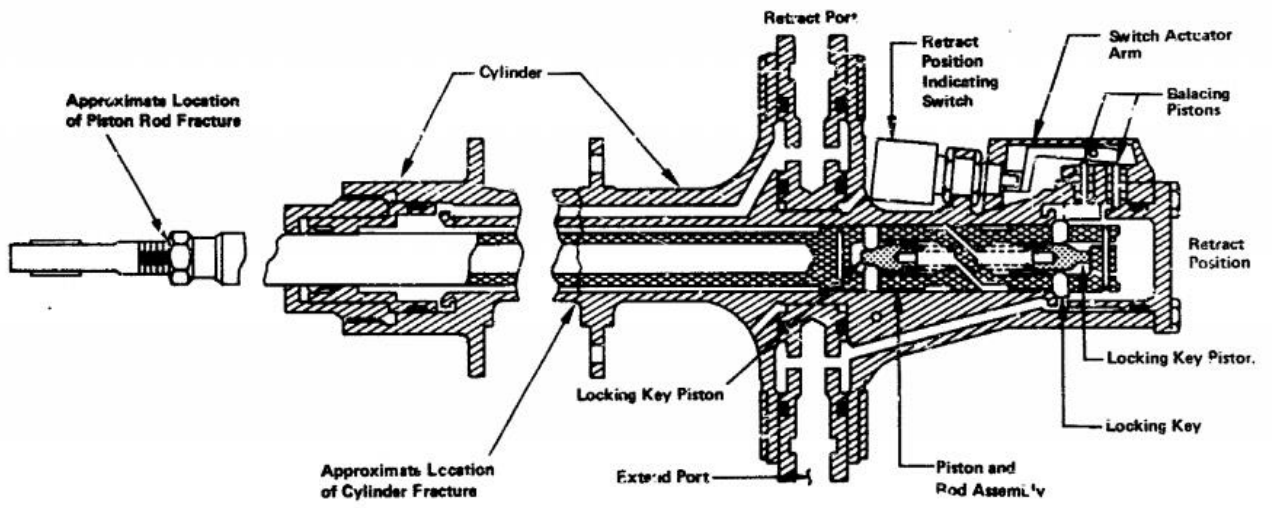
TYPICAL SLAT SECTION



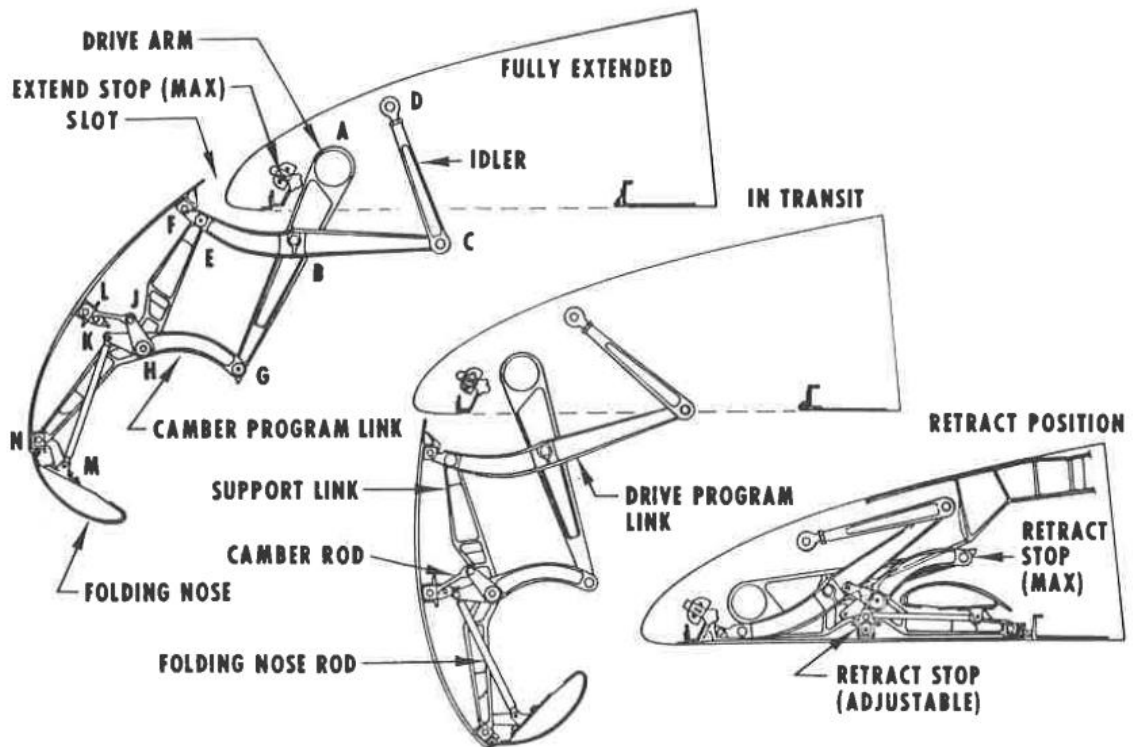
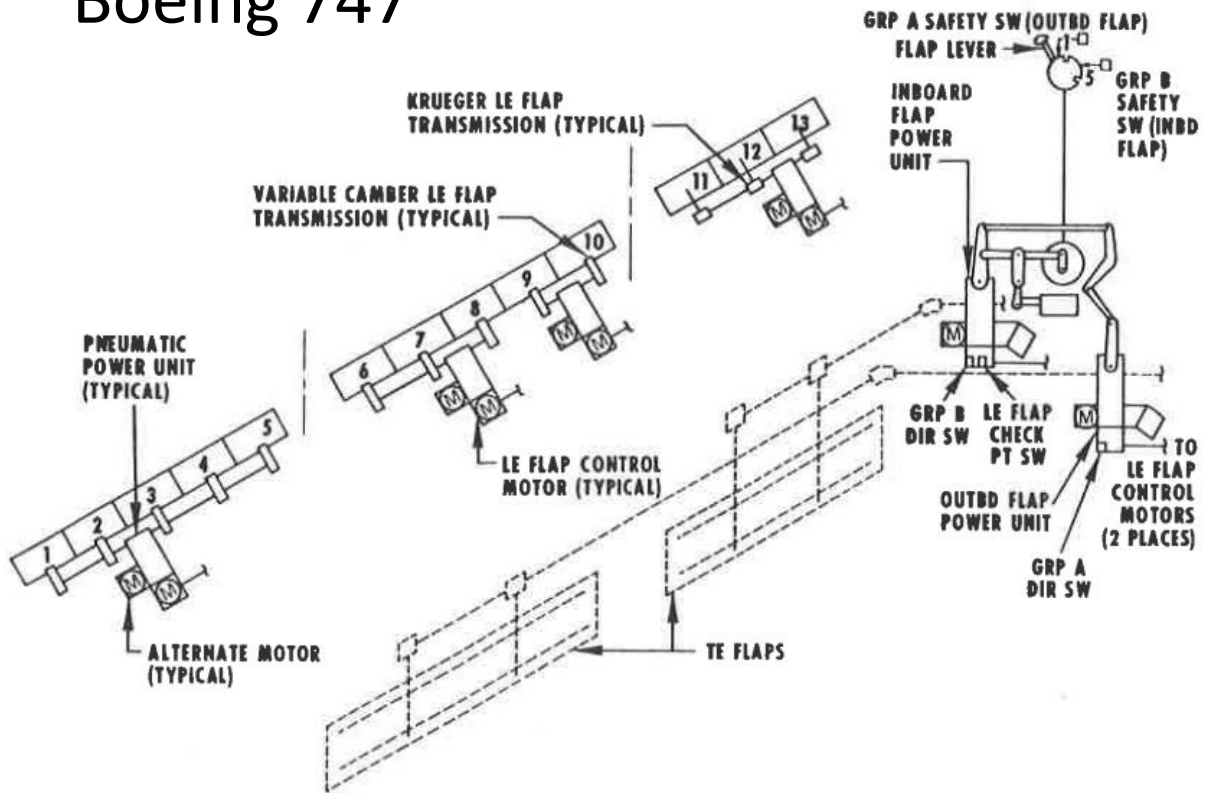
TYPICAL FLAP SECTION

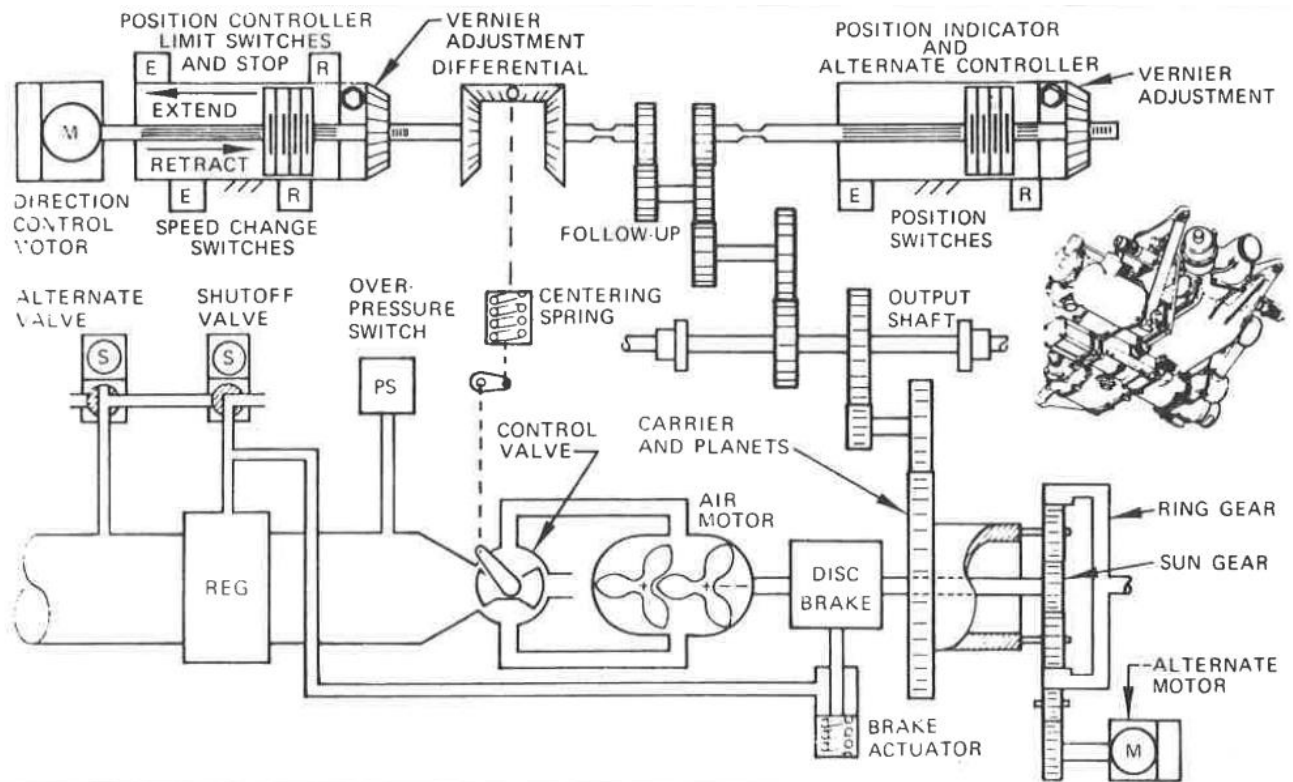


Photo Copyright Bruce Leihowitz



Boeing 747





Boeing 757

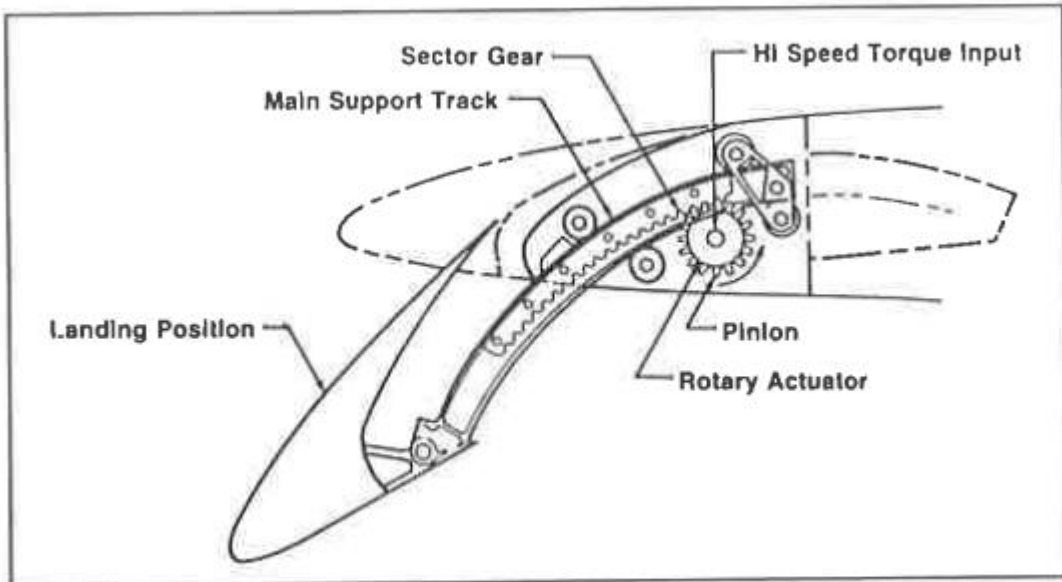
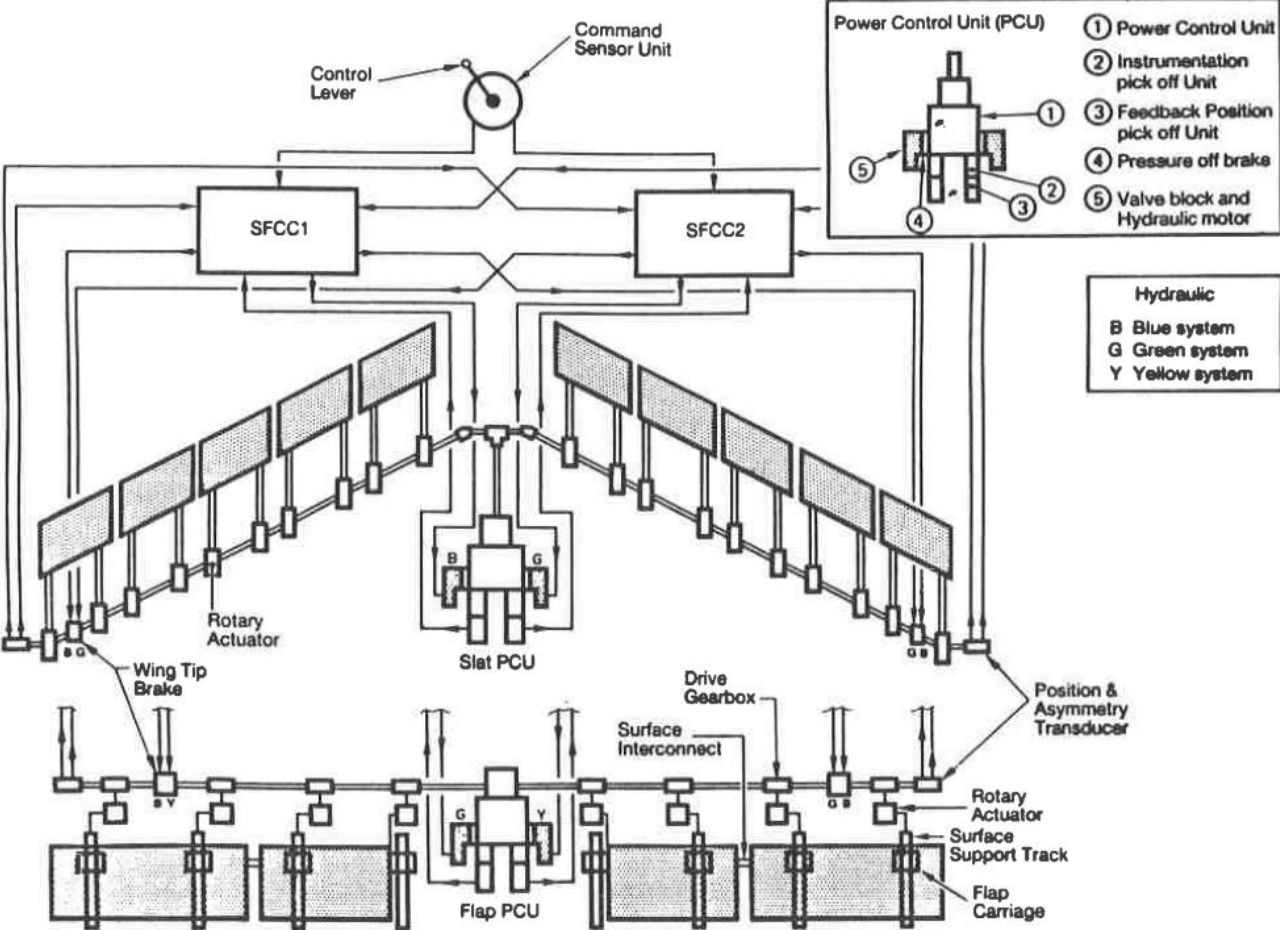
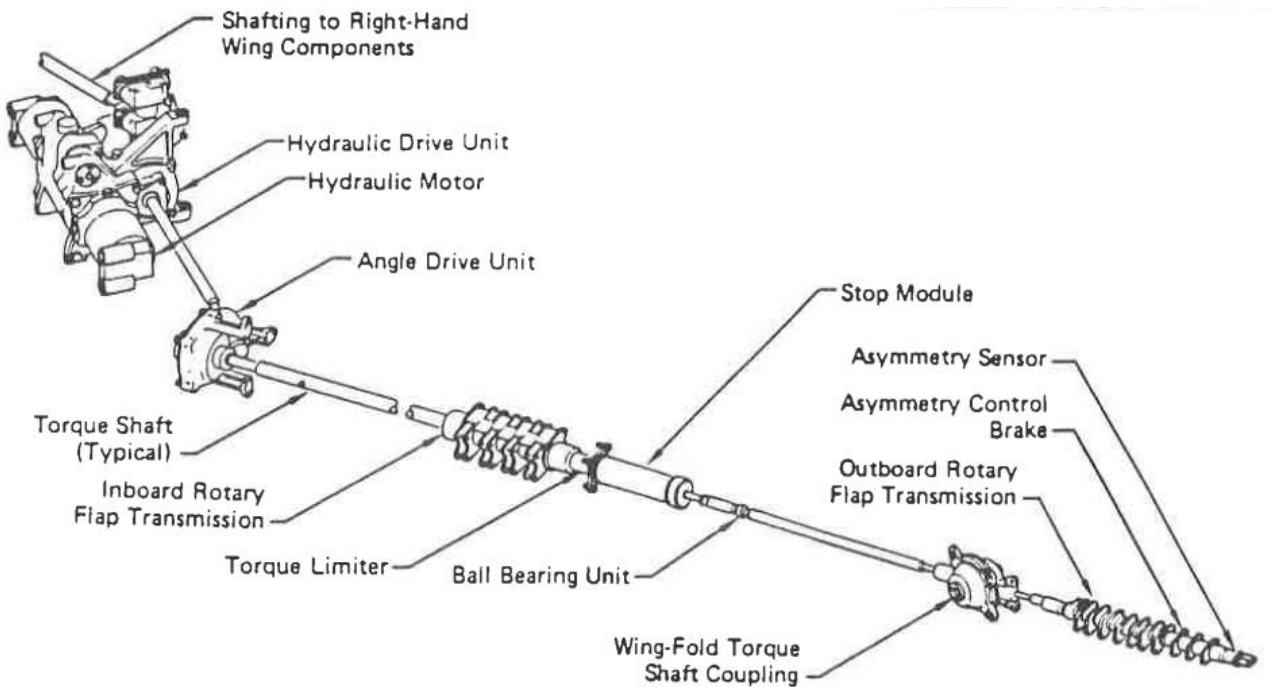
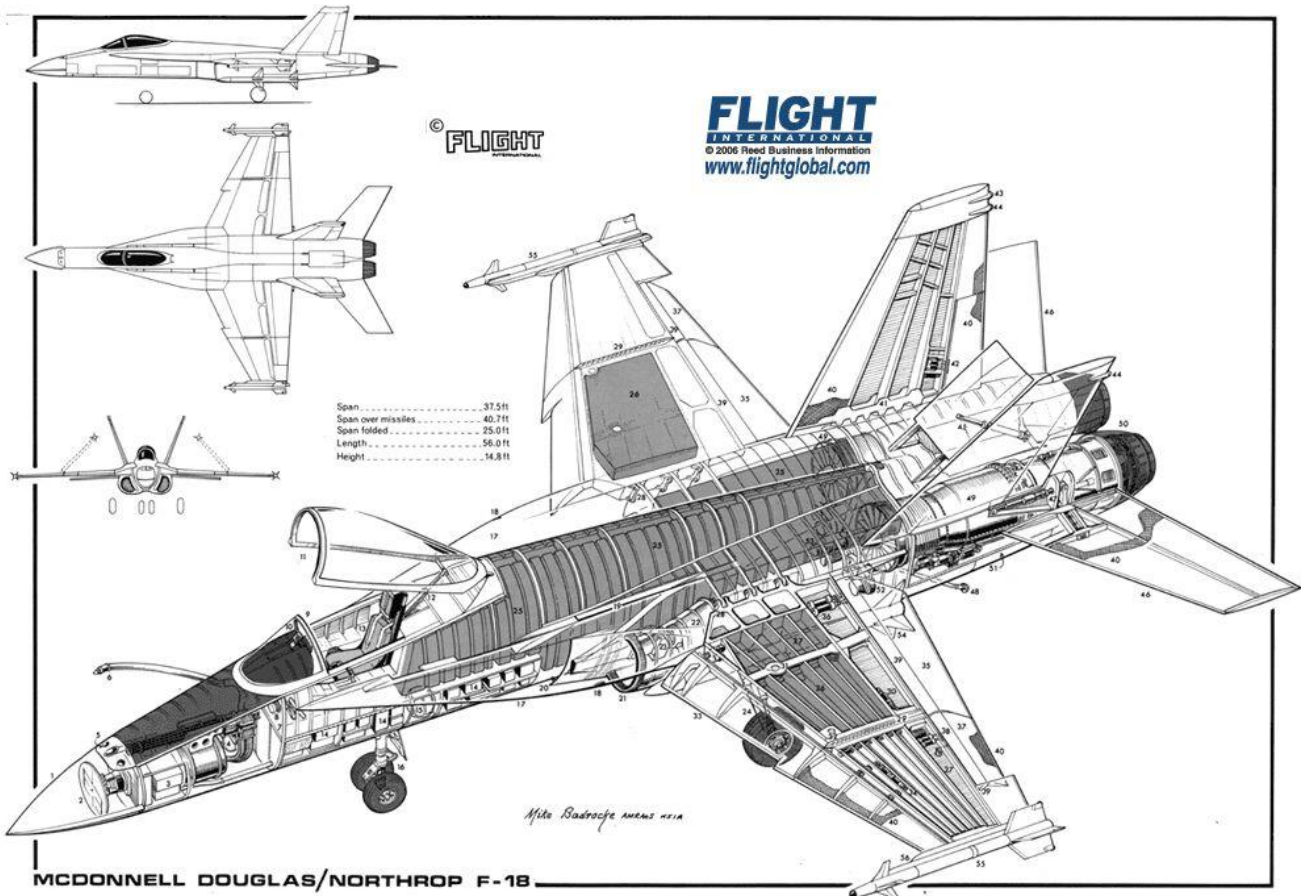


Figure 3-46. 757 Leading-Edge Slat Drive.

Airbus A320



F-18



A-4 Skyhawk: Simplicity

