

CUSTOMER TRAINING

39

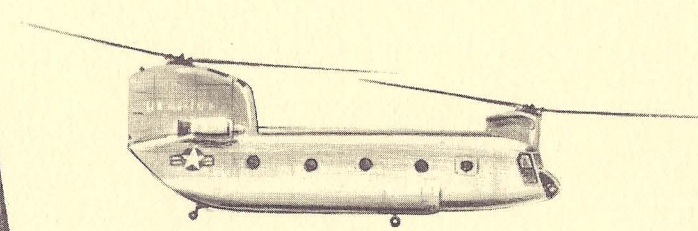

familiarization manual

CH-47

BOEING Helicopters

VERTOL DIVISION / MORTON PENNSYLVANIA U S A

NOTICE

This is not an official Department of Army publication. The information contained herein is for reference only and official approval is not to be implied. Where this information or any interpretation thereof appears to be in conflict with an official publication, the latter shall be followed. This publication will not be revised.

CH-47

FAMILIARIZATION MANUAL

BOEING Helicopters

VERTOL DIVISION / MORTON, PENNSYLVANIA. U S A

PRINTED
IN U.S.A.

APRIL 1967

FOREWORD

This manual has been prepared to supplement Boeing-Vertol customer training on the CH-47 Helicopter. It contains a general introduction to the entire aircraft via basic descriptions of the individual systems and subsystems.

Information is presented in a manner which will enhance the specific data found in the applicable CH-47 technical manuals by providing the foundation on which subsequent knowledge will be built.

Text data pertaining to the CH-47B model is presented in bold printing.

Illustrated data pertaining to the CH-47B model is presented in red.



TABLE OF CONTENTS

SECTION	PAGE	SECTION	PAGE
The CH-47 Helicopter	3	Rotary-Wing Blades (Droop Snoot)	41
Airframe	7	Flight Controls	43
Landing Gear	9	Stability Augmentation System	47
General Arrangement	11	Speed Trim System	51
Powerplant	13	Flight Control Hydraulic System	53
Fuel System	15	Flight Principles	54
Powerplant Control System	17	Hinge Points	55
Engine Start and Ignition	19	Control Actions	55
Anti-Icing Systems	21	Control Stick	56
Fire Detection and Extinguishing		Thrust Control	56
Systems	23	Directional Control	57
Auxiliary Power Unit	25	Automatic Speed Trim	57
Powertrain	27	Utility Hydraulic System	59
Engine and Combining Transmissions	29	Utility Hydraulic Subsystems	61
Forward and Aft Transmissions	31	AC-DC Electrical Systems	65
Transmission Lubrication	33	Cockpit Arrangement	67
Rotary-Wing Heads	35	Heating and Ventilation System	69
Rotary-Wing Controls	37	Cargo/Rescue	71
Rotary-Wing Blades	39	Armed CH-47	73

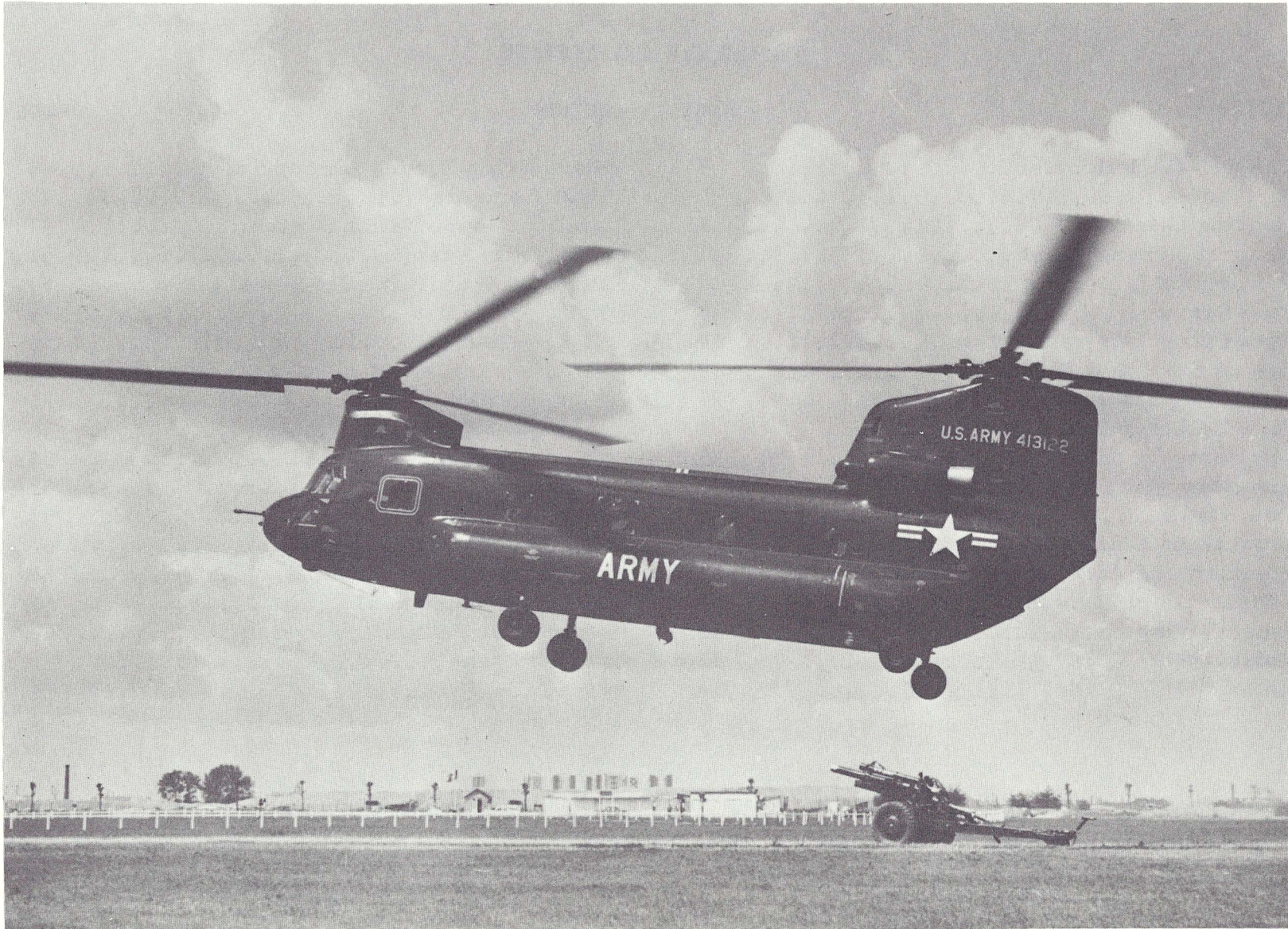



THE CH-47 HELICOPTER

In September 1958, following a design competition, a military selection board recommended that Vertol be selected to develop a new medium transport helicopter for the Army. By May 1959, specifications were approved and a contract issued. Now designated the CH-47A, the "Chinook" design and testing proceeded and the first flight took place in September 1961.

The "Chinook" is a twin-turbine-engine, tandem-rotor aircraft designed for transporting cargo, troops and weapons during all weather, visual, or instrument conditions. Powered by twin Lycoming T55-L-5 or T55-L-7 engines, the CH-47A develops 2,650 shaft horsepower and cruises at a normal speed of 130 knots at a maximum gross weight of 33,000 pounds. Rotor blades utilize a symmetrical airfoil.

A hydraulically boosted flight control system, supplemented by the Stability Augmentation System (SAS) provides the helicopter with flight characteristics similar to a fixed-wing aircraft.

A rear ramp permits rapid straight-in loading and unloading of troops, vehicles, and cargo.

A 16,000-pound capacity stowable cargo hook and a 3,000-pound capacity cargo-rescue winch are also provided. The aircraft has lifted a useful bulk cargo load of 10-1/2 tons.

The crew of the Chinook consists of a pilot, copilot, and crew chief. The aircraft accommodates either 44 combat-equipped troops or 24 patients using pole-type litters.

This versatile transport was designed with a minimum of maintenance requirements to be independent of elaborate ground support equipment. An installed auxiliary power unit (APU) permits ground operation of all utility systems without the need for external power sources.

The CH-47B model in current production is powered by twin T55-L-7C Lycoming engines which develop 2,850 shaft horsepower. Maximum gross weight has been increased to 40,000 pounds and speed capabilities have been improved with the addition of a nonsymmetrical airfoil rotor blade design and several minor system and fuselage modifications. This pertinent "B" model data appears under the appropriate headings and is displayed in bold printing.

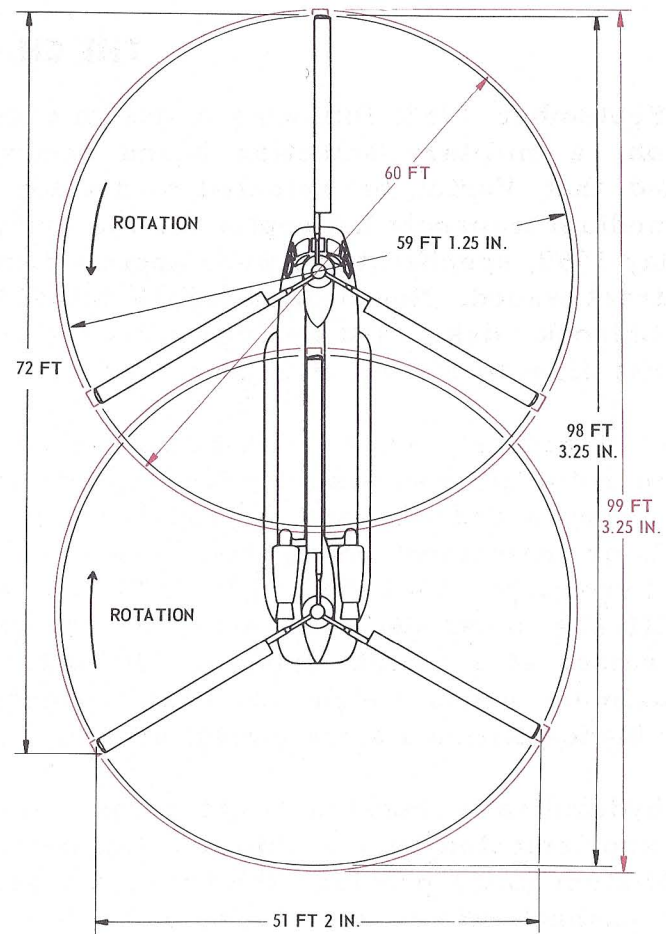
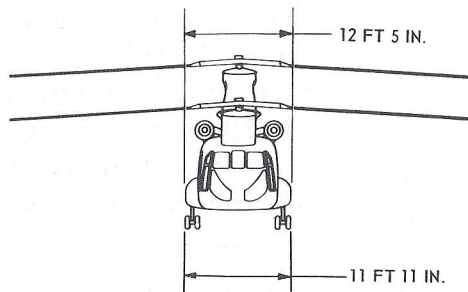
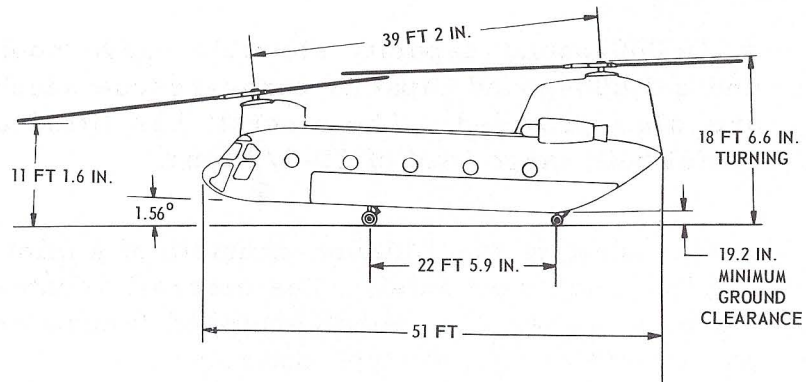

TYPICAL OVERALL DIMENSIONS

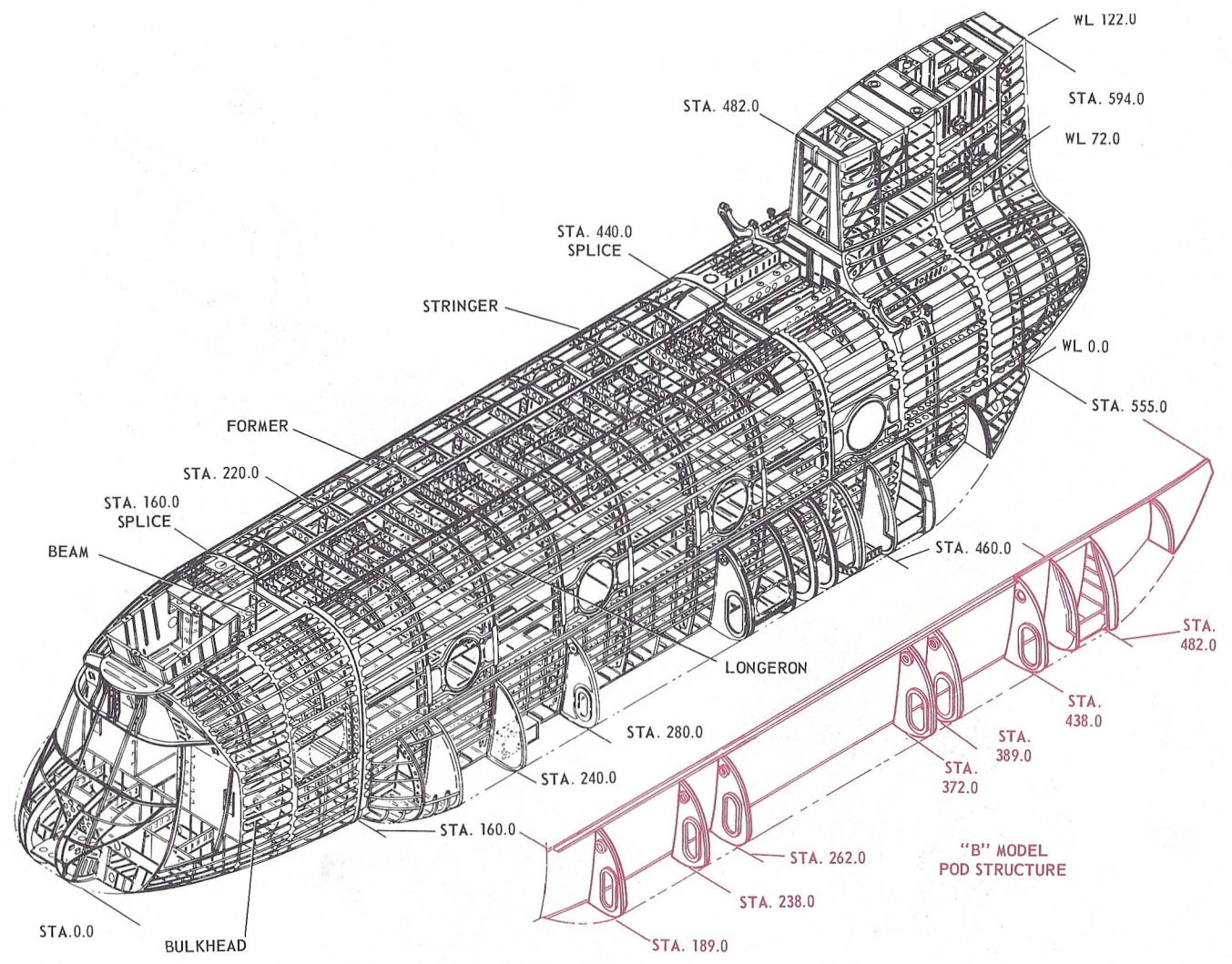

PRIMARY STRUCTURE

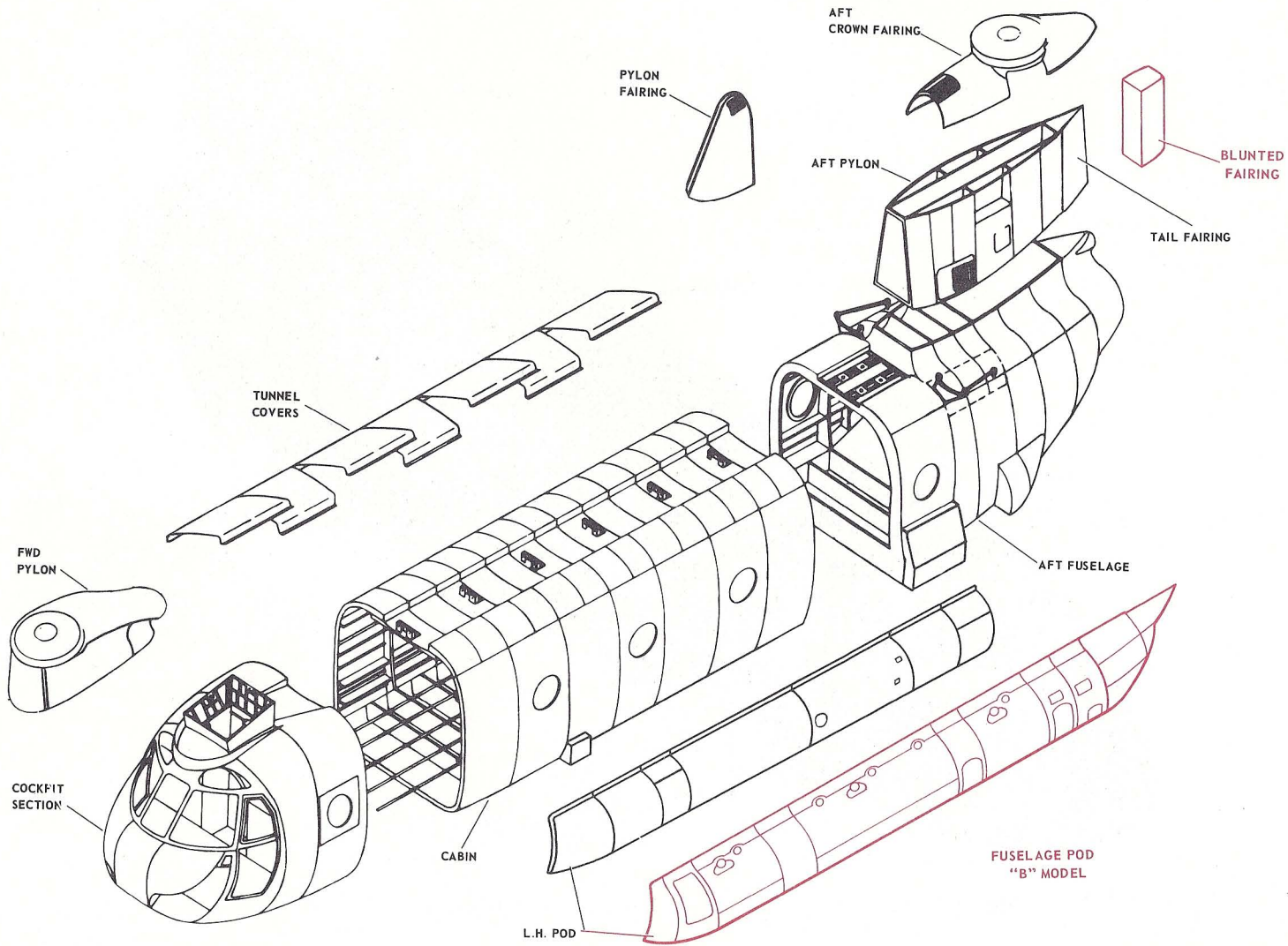

SECONDARY STRUCTURE



AIRFRAME

The CH-47 fuselage is of semi-monocoque construction, consisting of frames, stringers and bulkheads covered with stressed aluminum panels. Frames and bulkheads are the transverse members of the structure; stringers and longerons are the longitudinal members. Formers or beams are strategically located to support concentrated loads such as transmissions, powerplants and landing gear. The principal material used in fuselage construction is high-strength aluminum alloy.

The fuselage is divided into four sections: the forward cockpit, the cabin fuselage, the aft fuselage, and the aft pylon. The forward cockpit is completely fabricated and assembled prior

to splicing to the cabin fuselage section at station 160.00.

The cabin fuselage is a constant section composed of four panels: the crown, left and right side, and bottom. When covered by the cargo floor, the lower section forms a water tight compartment, necessary for water landing capability.

The aft fuselage section contains the cargo ramp and door, and is spliced to the cabin fuselage at station 440.00. The aft pylon is attached to the aft fuselage section at a field splice. To permit transportation of the helicopter within a limited space, the aft pylon can be removed.

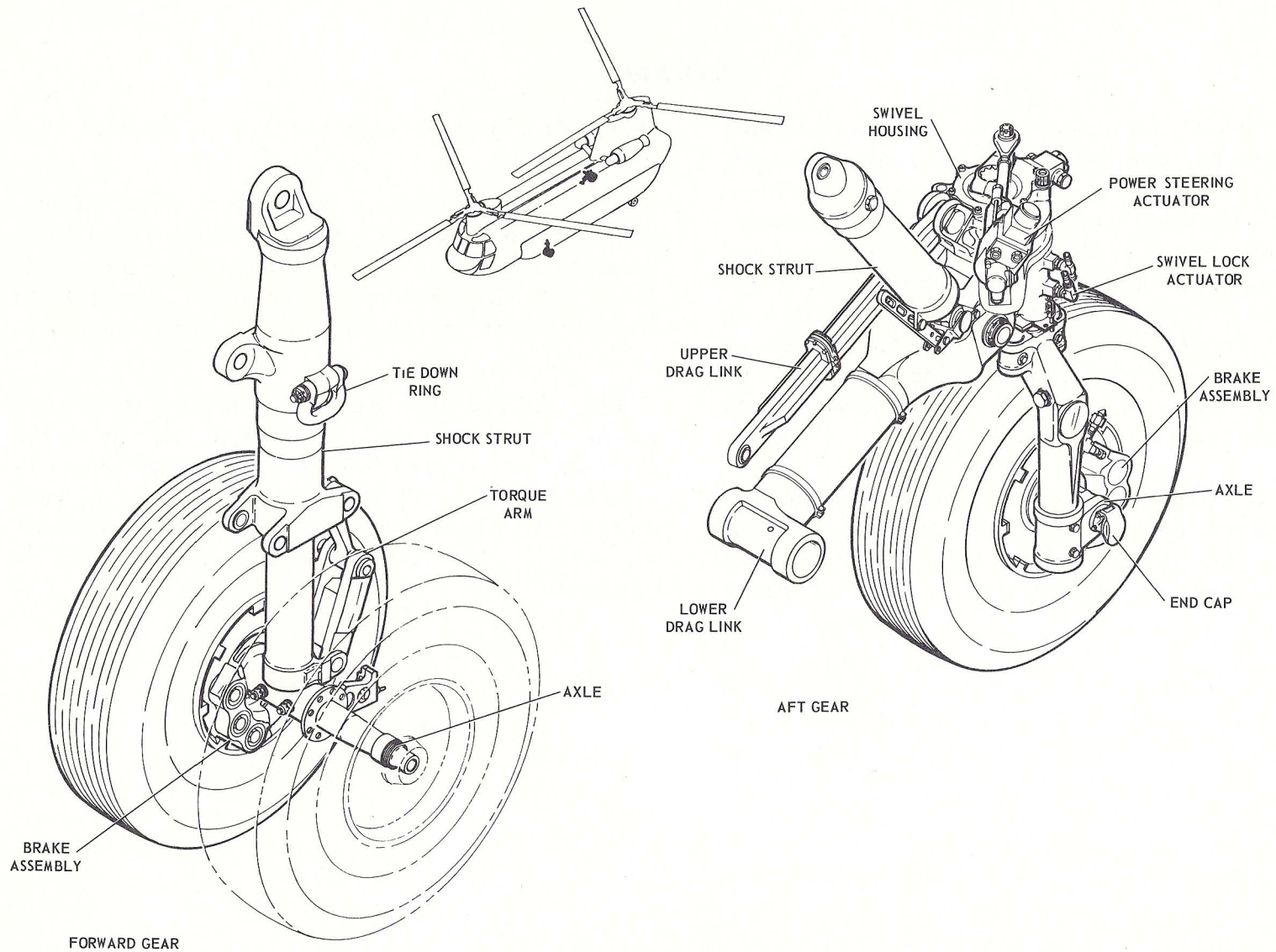

LANDING GEAR



LANDING GEAR

The landing gear system consists of four non-retractable landing gears: two forward and two aft. The forward landing gear assemblies are fixed non-swiveling type, with two wheels per assembly, while the aft gear utilizes one wheel per assembly. A power steering unit is installed on the right aft gear only. Some early CH-47A aircraft are equipped with standard aft gear with two wheels at each location, but without power steering.

The forward landing gears are interchangeable and each consists of an air-oil type shock strut and two brake assemblies. The upper section of the shock strut contains mounting lugs and is secured to the helicopter structure. The lower section contains the axle on which the wheel assemblies and brake assemblies are independently mounted. A scissor-type torque link assembly is connected between the upper and lower sections of the shock strut to prevent the lower section from turning.

Each aft landing gear consists of an air-oil type shock strut, two drag links, a swivel housing, an axle and one brake assembly. (Power

steering type gear only.) The upper end of the shock strut and the forward end of each drag link are secured to the fuselage; the other ends are secured to the swivel housing which assumes a trailing position.

The swivel housing includes a hydraulically operated cam for centering the wheels in the trailing position during flight, while a swivel lock is provided to secure them in this position when desired.

The landing gear brakes are hydraulically operated. Each wheel of the forward landing gear is equipped with a single brake disk and a 3-spot brake unit. The forward brakes are used for stopping and parking. To operate them, the brake pedals are depressed and the parking brake knob is pulled out.

Each wheel of the aft landing gear is equipped with a single brake disk and a 3-spot brake unit. On landing gear equipped with power steering, the aft brakes operate with the forward brakes when the swivel locks are engaged.

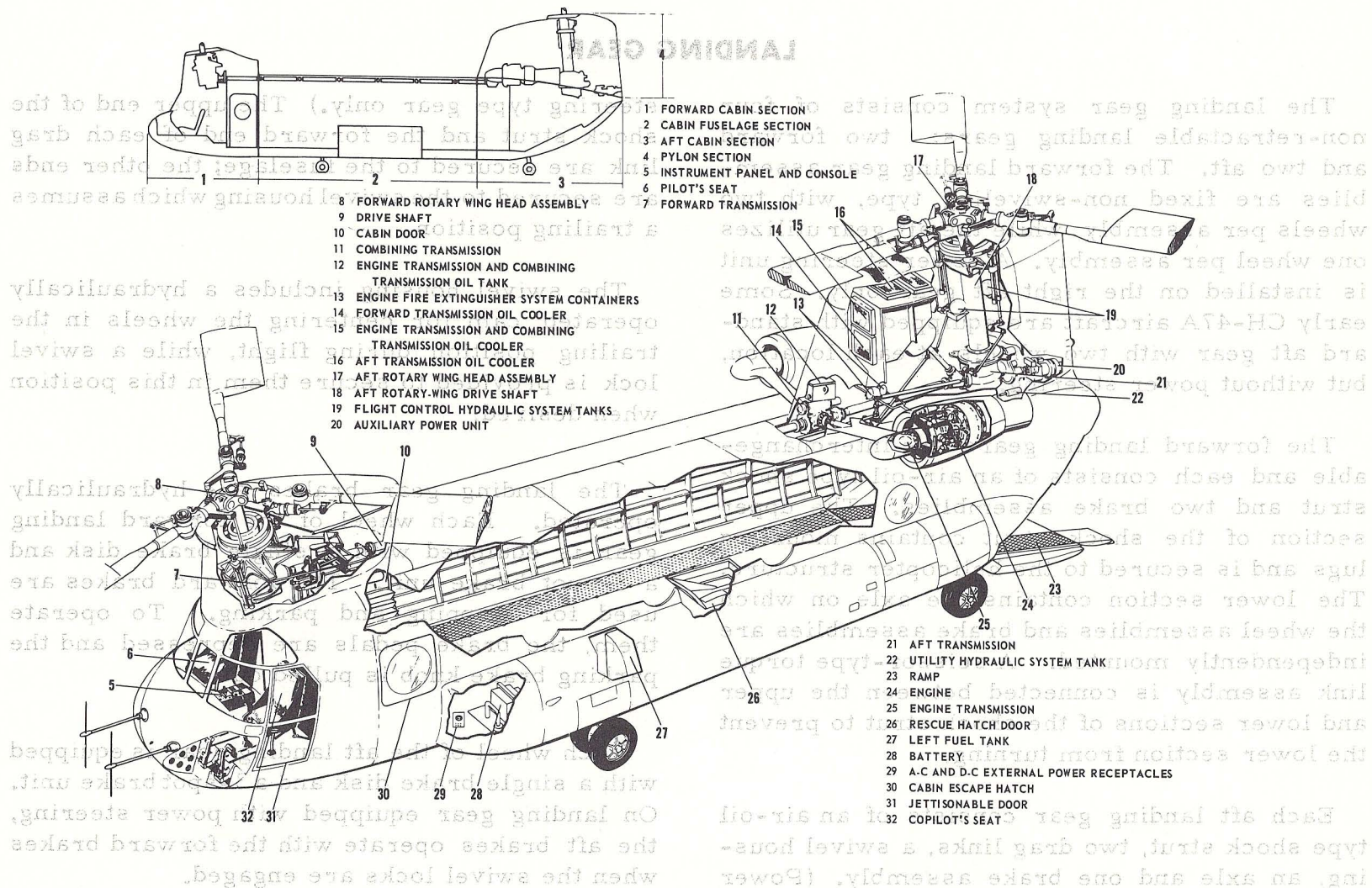

GENERAL ARRANGEMENT



GENERAL ARRANGEMENT

The cockpit section contains the forward transmission, the cockpit control assemblies, the pilot's and copilot's seats, the hoist winch, and the entrance door, which is located on the right-hand side. The door consists of two sections that open independently. The upper section rools upward on tracks and a latch holds it open; the lower is hinged at the bottom, opens outward, and contains an integral step. Two integral work platforms on the forward pylon fairing facilitate maintenance of the forward rotary-wing system.

The cabin fuselage section contains troop seating and provisions for litters, and serves as the major payload carrying area. Skid rails and tie-down rings are attached to the flooring to assist in the loading and securing of cargo. A rescue hatch is located in the cabin floor at the center of the section and an external cargo hook is located in the hatch compartment. Drain valves are located in the bottom skin to permit draining of the bilge area.

Fairing, forming a tunnel atop the cabin fuselage section houses the drive shafting, various flight control components, certain electrical cables, and hydraulic and lubrication lines. A walkway is located adjacent to the tunnel.

A detachable pod is located on each side of the cabin fuselage section. These pods house the fuel tanks, the mountings for the four landing gear, and certain components of the electrical and electronic systems.

The aft cabin and pylon sections contain the combining transmission, the aft transmission, related drive shafting, the auxiliary power unit, and the ramp. The engines are mounted externally on the aft fuselage section and are housed within individual nacelles. An engine transmission is mounted on the front of each engine.

Work platforms, integral with the fuselage, provide easy access to the engines. The aft pylon leading edge fairing is hinged to open like a clamshell for access to the combining transmission.

The CH-47B fuselage is similar in construction to that of the CH-47A. The right- and left-hand pods contain structural provisions for the addition of auxiliary fuel tanks forward and aft of the main fuel tanks. The aft pylon trailing edge is blunt with removable fairing. Strakes are incorporated on each lower side of the aft fuselage and ramp to provide increased directional stability.

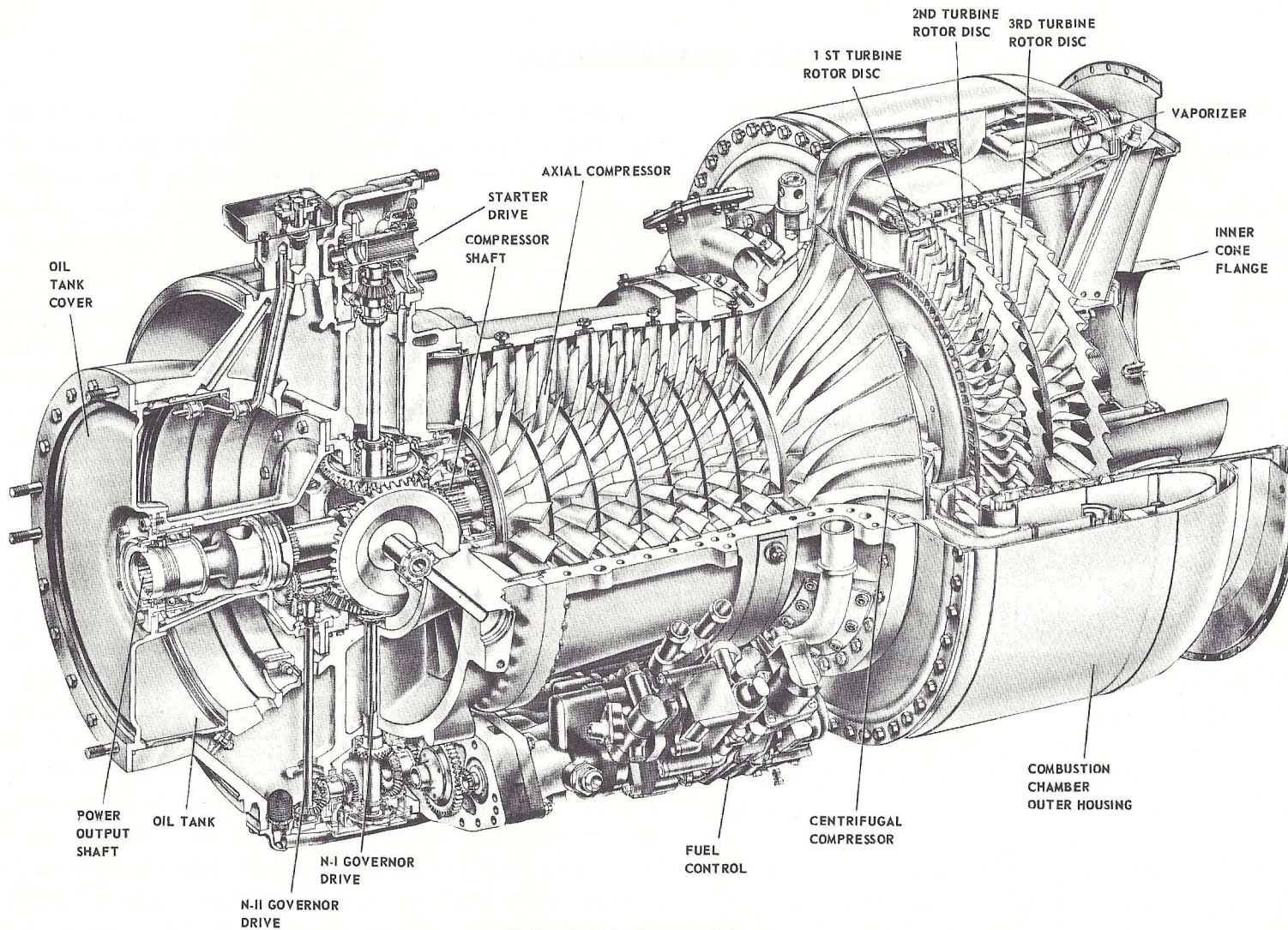

**CUTAWAY VIEW OF
LYCOMING T55-L (T55-L-7) SHAFT TURBINE ENGINE**



POWERPLANT

The CH-47A helicopter is powered by either two Lycoming T55-L-5 or two T55-L-7 shaft-turbine engines housed in separate nacelles mounted externally on the sides of the aft pylon section. The T55-L-5 is rated at 2,200 shaft horsepower at military power, while the T-55-L-7 engine is rated at 2,500 shaft horsepower at military power and, in addition, 2,650 shaft horsepower at maximum power. A modified fuel control and several internal improvements account for the power increase.

Each engine is made up of two sections: a gas producer section and a power turbine section. These two sections are not mechanically connected, but the hot gases produced by combustion flow from one unit to the other. During engine start, air enters the engine inlet and is compressed as it passes through various stages of the compressor rotor. The compressed air passes through a diffuser and into the combustion chamber, where it is mixed with starting fuel and ignited.

After the engine is started, it continues to operate on metered main fuel which is supplied to the vaporizers. Hot expanding gases leave

the combustion chamber and drive a compressor turbine which in turn drives the compressor rotor. Remaining energy from the combustion gases drives the power turbine which in turn drives the power output shaft of the engine transmission.

Maintenance, removal, replacement, or "quick-change" of either engine is facilitated by the location of the nacelles, the design of the engine mounts and the use of quick-disconnect couplings on all lines leading to the primary structure. Each engine is secured by three mounts: two forward and one aft. Normal access for maintenance is gained through hinged access doors on either side of the engine covers.

The CH-47B helicopter is powered by two Lycoming T55-L-7C engines of the same basic configuration as the earlier T55-L-5 and T55-L-7 engines. The T55-L-7C engine is rated at 2,850 shaft horsepower at maximum power. The major internal modifications which produce the increased power rating include the incorporation of a fuel atomizing combustor rather than a vaporizing type, improved spray nozzles for fuel injection, improved starting provisions and a modified fuel control.

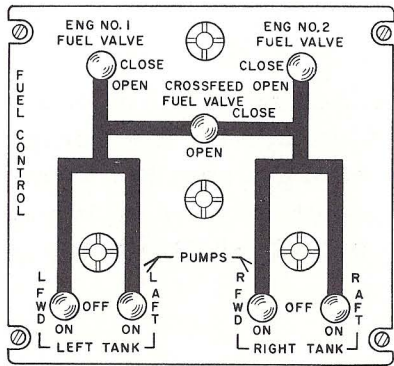

FUEL CONTROL PANEL

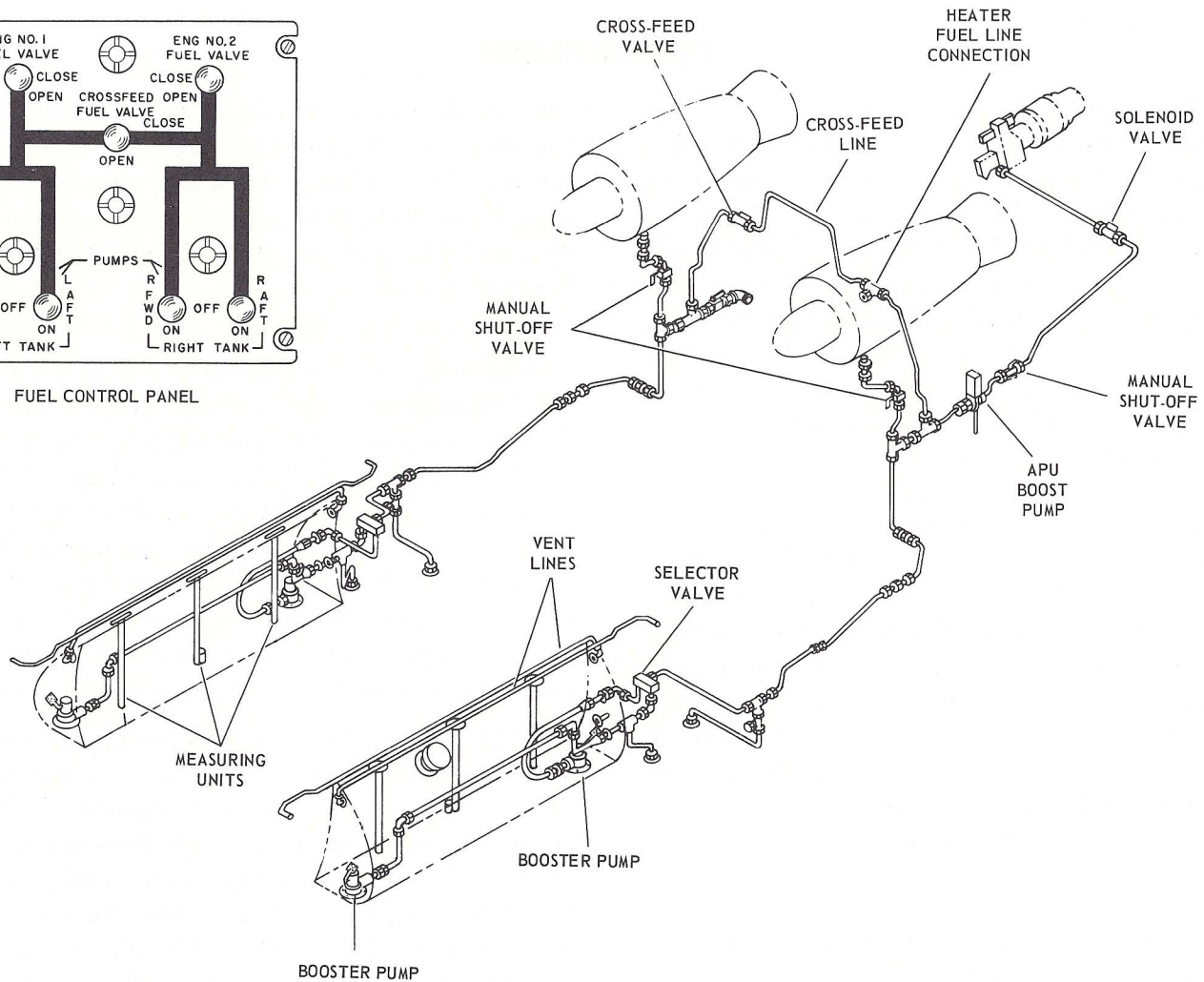

FUEL SYSTEM



FUEL SYSTEM

The fuel supply system furnishes fuel for the two engines, the auxiliary power unit (apu), and the heater. This system consists of two separate fuel systems which are interconnected by a crossfeed line and valve. The system is so designed that each tank normally supplies fuel to the corresponding engine. Under emergency conditions, either tank can be valved through a crossfeed system to supply fuel to both engines. During normal operation, fuel for the apu and the heater is supplied through the left-hand supply system; however, fuel can be supplied through the right-hand supply system thru the crossfeed system.

Each system consists of a fuel tank housed within a pod, three fuel quantity measuring units within each tank, two ac operated booster pumps, two float-controlled solenoid valves, and a fuel valve. Each booster pump delivers fuel through a series of valves and lines to the fuel control unit on the engine. If a booster pump fails and the fuel level in the tank is sufficient to cover both float switches, the solenoid valves will remain open and the engine fuel pump will continue to draw fuel from the tank. A check valve in the related line prevents fuel from being pumped back into the tank through the inoperative pump. If a booster pump fails

or becomes exposed due to low fuel level and aircraft attitude, and there is insufficient fuel to cover the float switch, the solenoid valve will close to prevent the engine fuel pump from drawing air through the exposed pump. In the event of low fuel pressure, a caution light for the respective system warns the pilot. The fuel supply to a malfunctioning engine can be shut off by pulling the fire control handle in the cockpit. This electrically actuates the fuel valve.

The interchangeable fuel tanks each have a 315-gallon (2047.5 pounds) capacity. Newer self-sealing tanks have a capacity of 310.5 gallons (2018.25 pounds).

Vent lines extend along the top of each fuel tank; fuel cannot escape from these lines in normal helicopter attitudes. Fuel quantity for each tank is read on a common indicator through the use of a selector switch. When the switch is turned to the indicated tank, a capacitive signal is received from the measuring units in that system only and the fuel quantity is indicated on the indicator. Total fuel in all tanks is indicated when the switch is on TOTAL. A caution light for each tank warns the pilot when there is 20 percent of fuel (by volume) remaining in the corresponding tank.

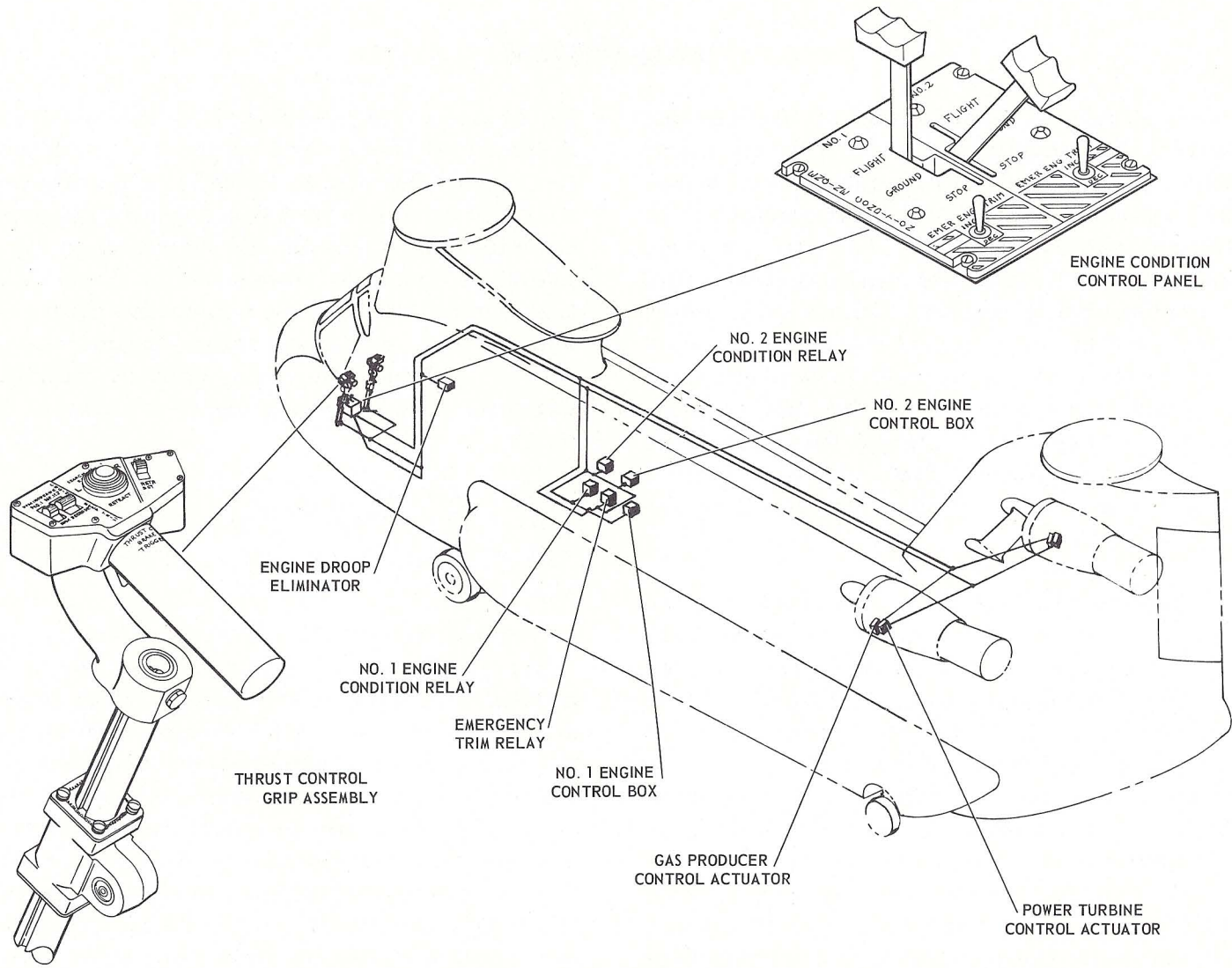

POWERPLANT CONTROL SYSTEM



POWERPLANT CONTROL SYSTEM

The powerplant control system provides independent remote control of each engine. There are two subsystems within each engine control system: a gas producer control system and a power turbine control system.

The controls for the gas producer section consist, primarily, of an engine condition lever on the console, an actuator on the engine, and a fuel control unit. The speed of the gas producer section of the engine is controlled by the gas producer lever on the engine fuel control unit. Movement of the engine condition lever electromechanically positions the gas producer lever which programs fuel to the gas producer section. When the engine condition lever is in STOP, fuel to the gas producer section is shut off; when the lever is in GROUND, starting fuel is programmed; and when the lever is in FLIGHT, maximum fuel is permitted to flow to the gas producer section.

The controls for the power turbine section consist of two beep trim switches on each thrust control stick, two emergency engine trim switches on the engine condition control panel, two dual droop-eliminator variable resistors

(potentiometers), two beep trim relays, an emergency engine trim relay, two adjustable resistors, an engine condition control box, and an actuator connected to the turbine speed selector lever on the engine fuel control unit. The speed of the power turbine section of the engine is controlled by the power turbine speed selector lever. One beep trim switch operates the power turbine lever actuators of both engines to regulate the power turbine and rotary-wing rpm by increasing or decreasing the fuel supply. The second beep trim switch positions the power turbine lever of the No. 1 engine to match the output torque of the two engines. The engine beep trim circuits control power turbine rpm only when the related engine condition lever is in FLIGHT.

The droop eliminator potentiometers, mechanically linked to the thrust control system, cause the power turbine lever to move when the thrust control setting is changed, thereby automatically compensating for variations in power turbine speed which are caused by changes in power demands on the engine. The emergency trim switches are used to change the speeds of the power turbines if the normal beep trim system malfunctions.

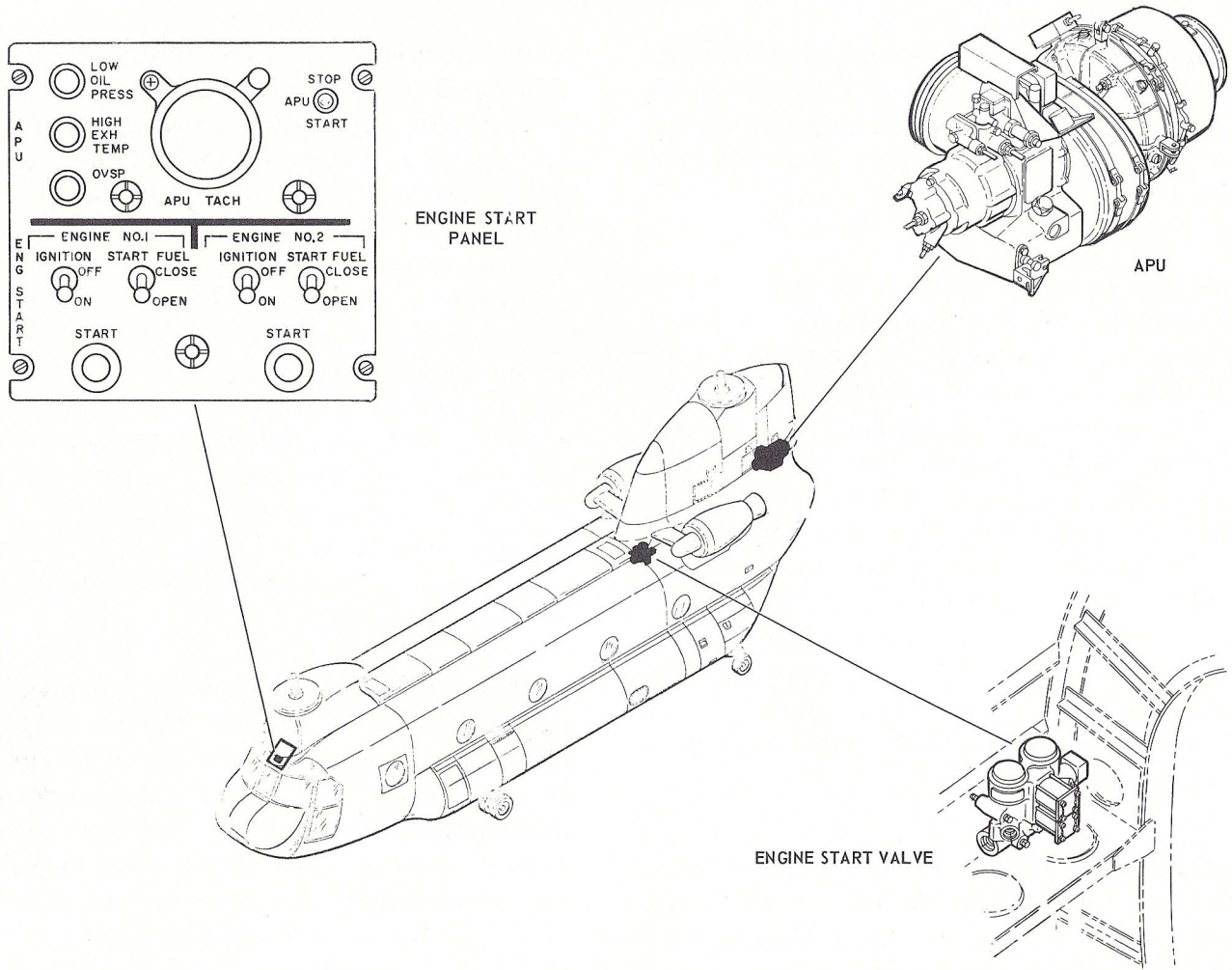

ENGINE START AND APU



ENGINE START AND IGNITION

The helicopter contains a separate starting and ignition system for each engine. Each ignition system consists of an ignition exciter, two igniter plugs, an ignition lead assembly, an ignition switch, and the necessary switches, relays, and wiring required to interconnect the starting and ignition systems.

The ignition exciter converts low voltage dc to pulsating high voltage through the use of a vibrator and a transformer. The high tension current is carried by the ignition lead assembly from the exciter to a spark splitter which contains high voltage coils. High voltage is then distributed by the ignition lead assembly to two igniter plugs in the engine.

Each engine has a hydraulically powered starter motor. The hydraulic pressure which operates the starter motor is provided by the utility hydraulic system. (See Utility Hydraulic System and APU System for details.)

To start either engine, the respective engine condition lever is moved from the STOP posi-

tion to the GROUND position, the starting fuel switch is moved to the OPEN position, and the ignition switch is turned ON. When the start switch is depressed, hydraulic power, starting fuel, and ignition are automatically supplied to that engine. Simultaneously, the engine start valve opens allowing utility system hydraulic pressure to be provided to the proper engine starter motor. When the utility system valve closes, the engine begins to motor or rotate.

At approximately 12 percent engine rpm, a percentage of main fuel is metered to the engine along with the starting fuel. As the engine rpm increases, the percentage of main fuel to the engine is increased.

The engine can be motored by depressing the start switch when the starting fuel switch is in CLOSE, the ignition switch is OFF, and the engine condition lever is in STOP. When this procedure is followed, the engine will continue motoring only while the start switch is depressed.

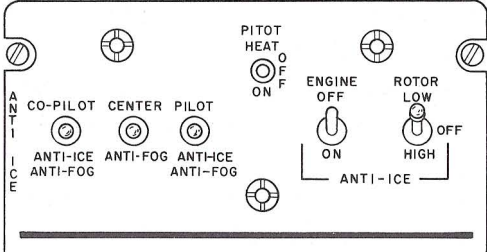
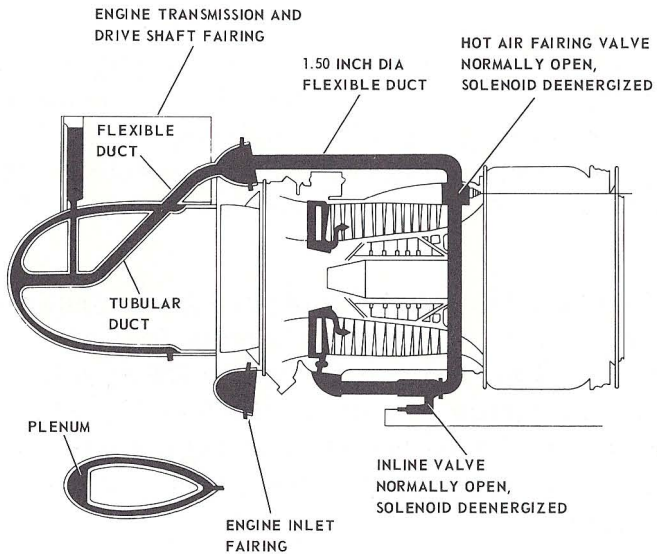
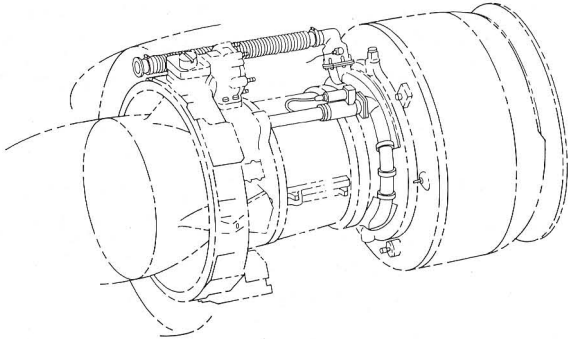
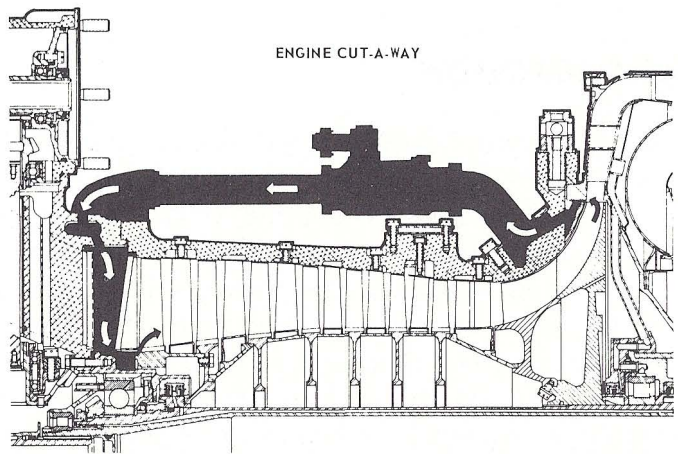

ENGINE ANTI-ICE



ANTI-ICING SYSTEMS

There are four anti-icing systems installed in the helicopter which protect the engine, portions of the structure, the pitot tube, SAS yaw ports, and the windshield. These systems are controlled from the anti-ice panel of the overhead switch panel.

The engine anti-icing system is a function of two sources: hot air ducted to the inlet guide vanes and thermal radiation produced by the oil tank located within the inlet housing. An electrically operated engine hot air valve is positioned on the top left-hand side of the engine compressor housing, directly behind and to the left of the starter drive housing. When opened, the valve allows hot air to flow from the compressor diffuser section to the internal passages of the inlet housing, preventing the formation of ice on the hollow inlet guide vanes. Additional anti-ice protection is provided by thermal radiation from the hot oil in the oil cavity of the

inlet housing which warms the air as it passes into the engine inlet.

Anti-icing is also provided for the engine air inlet fairing, engine transmission fairing, and the drive shaft fairing. Hot air is tapped from the engine air bleed gallery, through a valve and ducted to the leading edge of the fairing, where it circulates before escaping through small holes in the trailing edges. To prevent ice accumulation in the pitot tube and SAS yaw ports, electrically operated heating elements are provided at each location.

The pilot's and copilot's windshields are anti-iced and defogged electrically. The center windshield is defogged only. The laminated plastic windshield panels are heated by current passing through a transparent conductive coating embedded between the layers. The temperature of each individual windshield is automatically maintained by a sensor element and controller.

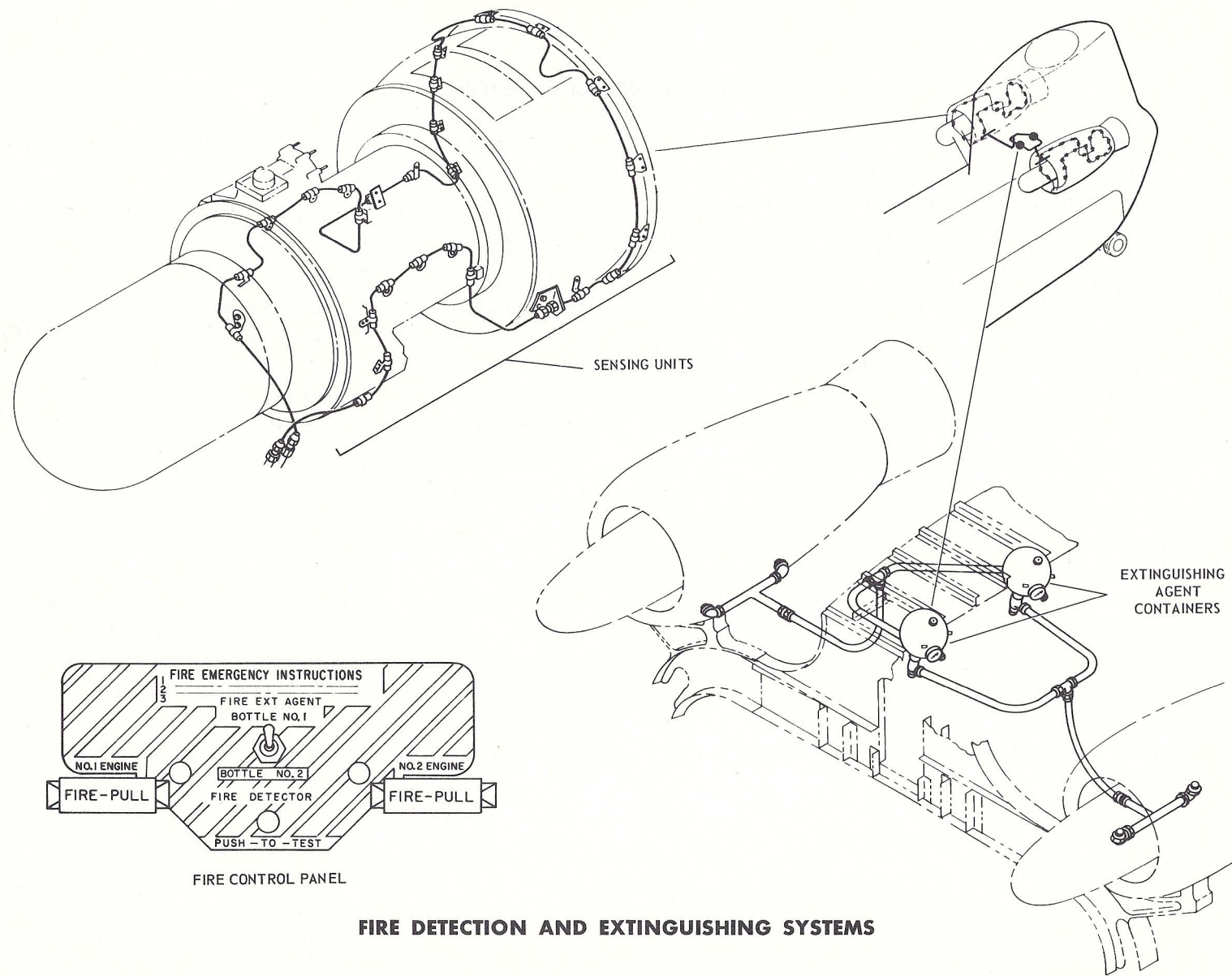

FIRE DETECTION AND EXTINGUISHING SYSTEMS



FIRE DETECTION AND EXTINGUISHING SYSTEMS

The fire detection system consists of two identical circuits, one circuit for each engine compartment. Each circuit consists of three series-connected, continuous-type, sensing elements which are routed around the engine and a control unit mounted on the airframe.

When either fire detection circuit is energized by an abnormal increase in the engine temperature, the corresponding fire control handle on the instrument panel illuminates.

The sensing elements are constructed of Inconel tubing with a nickel wire center conductor that is surrounded by a salt compound and insulation. The elements are hermetically sealed with water-tight electrical fittings at their ends. The tubing can be bent or rebent to a radius of not less than one inch. The hermetically sealed control unit contains a test circuit relay.

A test switch located on the instrument panel is used to check the operation of the fire detection system. When the switch is pushed in, a relay in each control unit closes which completes the circuit, and the fire warning lights come on.

The fire extinguishing system consists of two fire control handles and a fire extinguisher agent switch located on the instrument panel and two extinguishing agent containers mounted in the aft pylon. The containers are partially filled with bromotrifluoromethane (CB_2F_3) and pressurized with nitrogen. When either fire control handle is pulled out, the respective engine fuel valve is closed and the fire extinguisher agent switch is armed. The agent in either one or both containers can then be discharged into either engine compartment through interconnecting tubing by selecting the desired container with the agent switch.

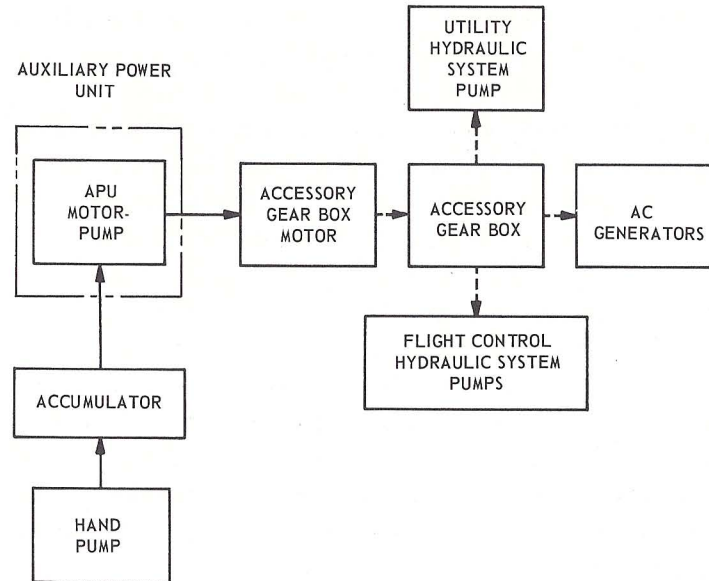
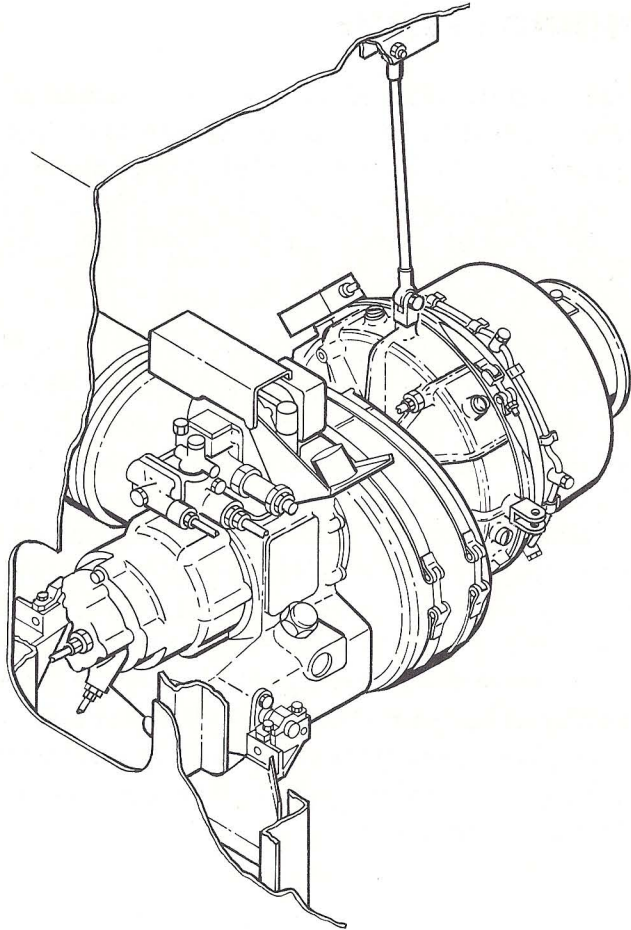

AUXILIARY POWER UNIT



AUXILIARY POWER UNIT

The auxiliary power unit (apu) consists of a gas turbine engine, hydraulic motor-pump and the fuel control. The apu provides hydraulic pressure from the motor-pump to hydraulically actuate the accessory gear box (agb) pump, thus supplying the necessary 4,000 psi pressure to actuate the main engine starter motors. Two ac generators, two flight control hydraulic system pumps, and a utility hydraulic system pump are mounted on the agb. Thus, the apu is capable of supplying the necessary power required for the ground operation of all the helicopter systems.

Normally, for starting the apu, the accumulator is pressurized by previous operation of the utility hydraulic systems. However, an

installed hand pump can be utilized to pressurize the accumulator.

Internal sensing switches in the apu system protect against abnormal operation conditions, including overspeeding, excessive exhaust gas temperature, and low oil pressure. The apu control switch, tachometer, and warning lights are located on the overhead switch panel.

The auxiliary power unit is mounted in the lower section of the pylon. The forward end of the unit rests on two pad-type supports which are attached to the airframe. The aft end of the unit is supported by two links, a vertical link at the 12 o'clock position and a horizontal link at the 9 o'clock position. Both links are bolted to the airframe at one end and to a fitting which is threaded into the apu at the other end.

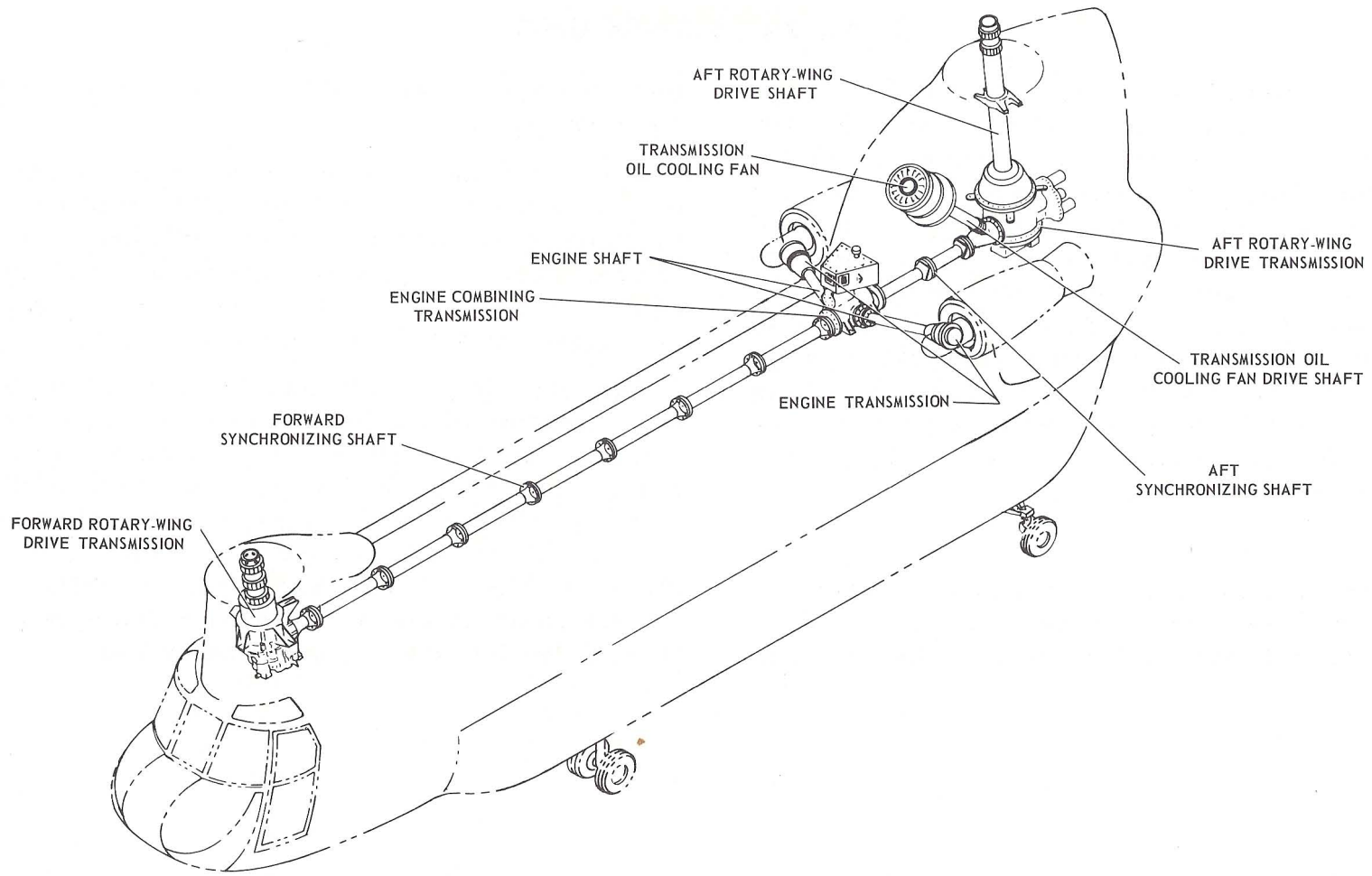

POWERTRAIN



POWERTRAIN

The CH-47 powertrain consists of five transmissions, interconnecting drive shafting, the aft vertical shaft, and the oil cooler fan assembly. One drive shaft (engine shaft) is connected from each engine transmission to the combining transmission.

Seven sections of shafting (forward synchronizing shaft) are connected from the combining transmission to the forward transmission; and two sections of shafting (aft synchronizing shaft) are connected from the combining transmission to the aft transmission. Two shafts are driven by the aft transmission: one (aft vertical-drive shaft), drives the aft rotary-wing head, and the other (fan drive shaft), drives an oil-cooling fan.

The shafts are seamless aluminum alloy tubes. The engine shafts, the oil cooler fan shaft, and the aft section of the forward synchronizing shaft have forged aluminum adapters riveted to each end. The first six sections of the forward synchronizing shaft, which are interchangeable, have forged aluminum adapters riveted to one end and an internally splined steel adapter. The adapter contains a shaft bearing and housing assembly and a flexible coupling.

The aft vertical drive shaft has steel splines at both ends.

Each shaft and adapter assembly is dynamically balanced as a unit. The shafting is supported by shock mounts which are attached to the bearing housings and secured to the structure.

Flexible couplings, consisting of stainless steel plates are used to absorb differential action at each shaft-section juncture, excepting the aft vertical shaft. The couplings are also bolted to the transmission and oil cooler adapters. The shafts are, in turn, bolted to the couplings. The adapters and their respective couplings are individually balanced as units.

The aft synchronizing shaft is constructed and supported in the same manner as the forward shafting. However, the two sections of the aft synchronizing shaft are not interchangeable.

The aft vertical drive shaft is externally splined at each end to mate with the internal splines of the aft transmission and the aft rotary-wing hub. A thrust bearing and housing assembly is installed over the upper section of the shaft and is bolted to the pylon structure.

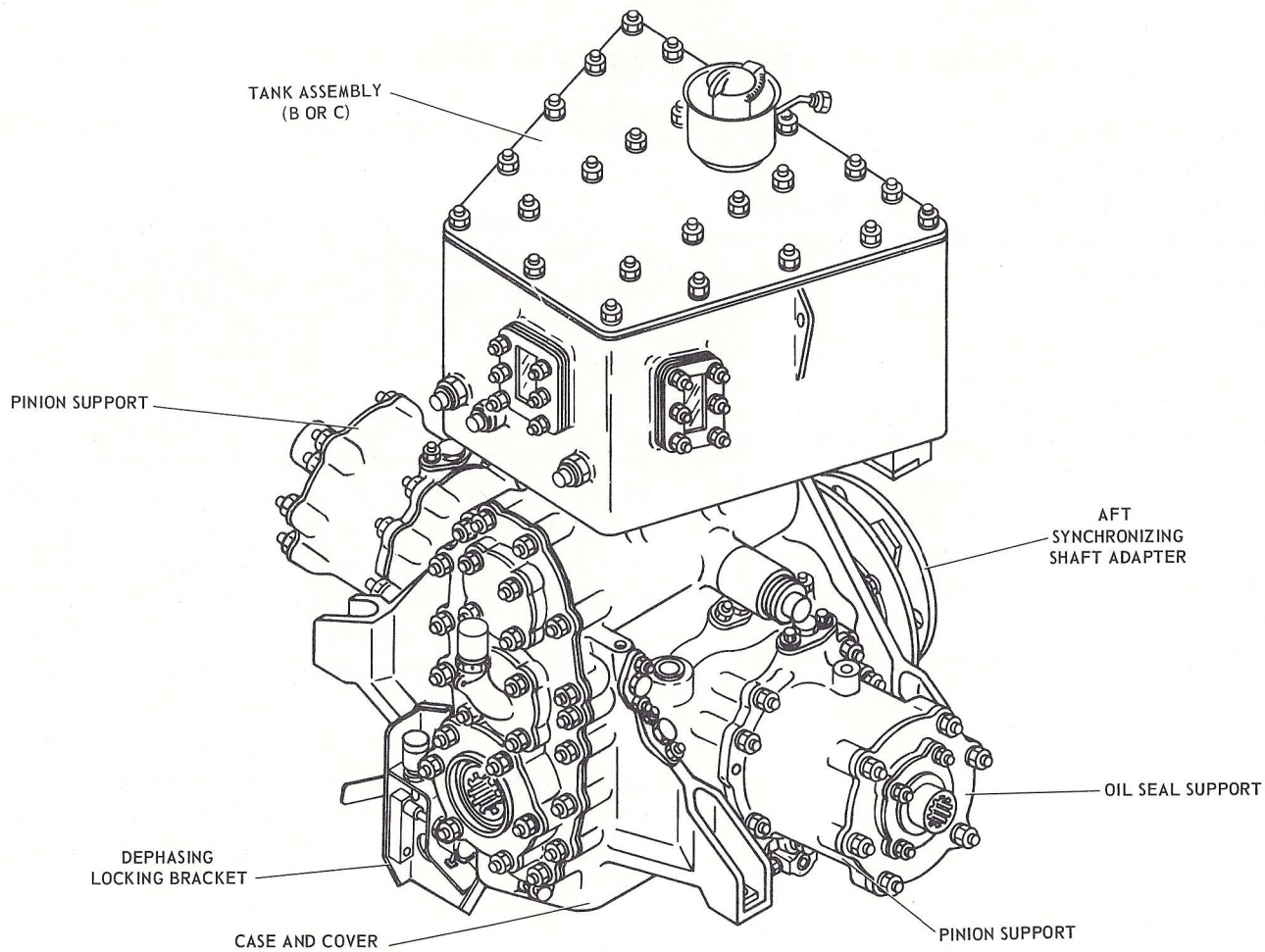
**COMBINING TRANSMISSION**



ENGINE AND COMBINING TRANSMISSIONS

The engine transmissions are attached to the forward end of each engine. Power from each engine is supplied to the respective transmission by way of a quill shaft, which drives the spiral bevel pinion gear. The spiral bevel pinion gear drives the spiral bevel gear and shaft assembly where the direction of torque is changed 90 degrees. Torque is then transmitted through a one-way drive, overriding (sprag) clutch to the output shaft. The sprag clutch permits the rotary-wing system to override the engine during autorotation or in the event of an engine failure. A speed reduction of 1.26:1 occurs within the engine transmission.

Torque is transmitted from the engine transmissions to the combining transmission by the engine shafts.

The two engine transmissions are identical and can be used in either position by making a minor mechanical conversion.

The combining transmission receives the torque delivered from both engine transmis-

sions and distributes the combined torque to the forward and aft transmissions.

The torque from both engines is combined within the transmission by means of two spiral bevel input pinion gears and a single spiral bevel ring gear. The spiral bevel input pinion gears receive the torque from the engine transmissions and both gears drive the ring gear. A speed reduction of 1.70 to 1 occurs at this point.

The transmittal of longitudinal torque is accomplished by forward and aft output shafts; the ring gear is bolted to the aft shaft. The two shafts are connected by a bearing mounted sliding coupling. The coupling permits engagement and disengagement of the forward and aft synchronizing shafts. The coupling mechanism is manually operated by means of a handle mounted on the right-hand side of the transmission. Two sensitive switches break the engine starting circuit if the handle is in the disengaged or unlocked position.

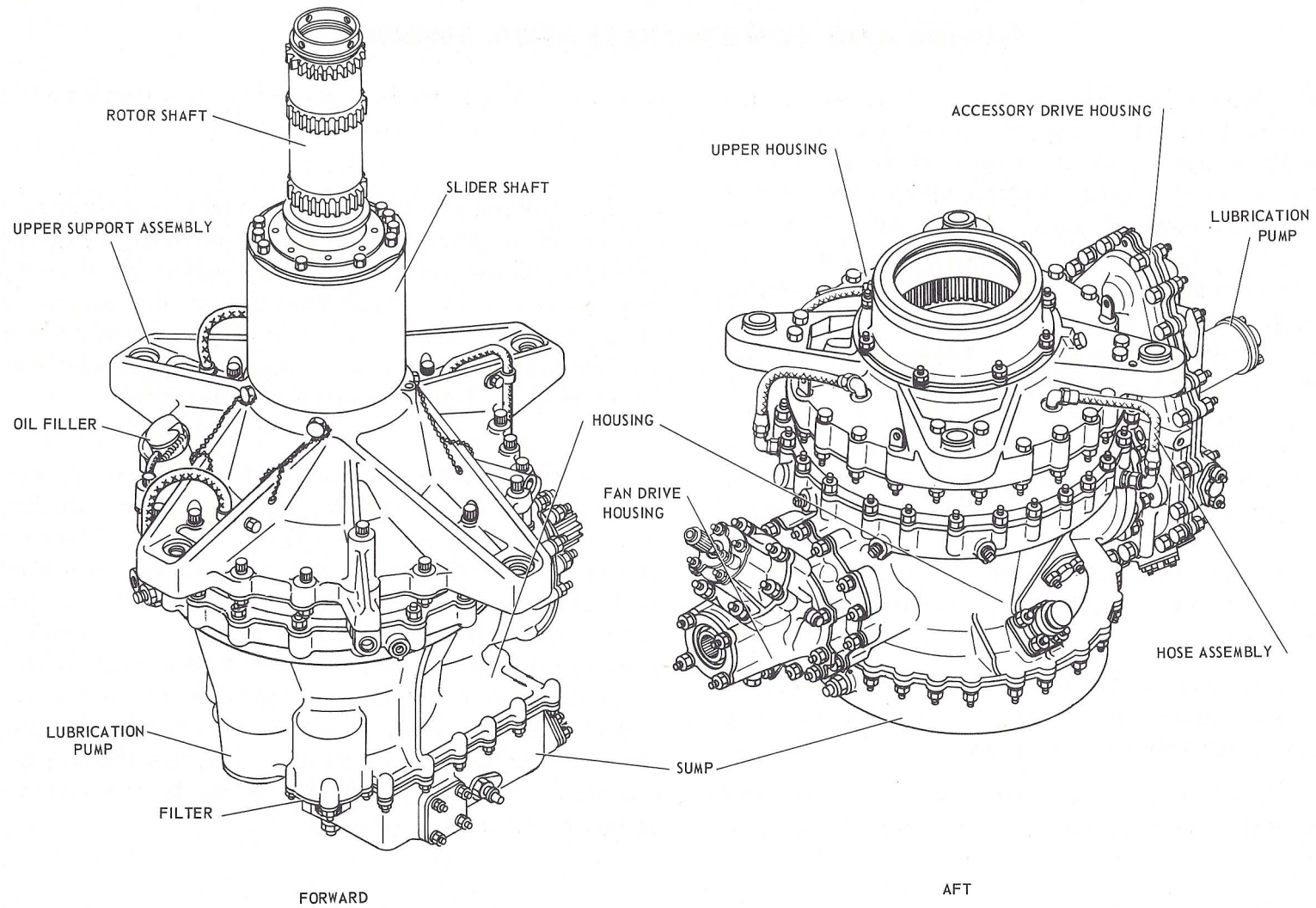

TRANSMISSIONS



FORWARD AND AFT TRANSMISSIONS

The forward and aft transmissions transmit torque from the combining transmission to the respective rotary-wing heads. Torque is transmitted within the transmissions by a spiral bevel input pinion gear which meshes with a spiral bevel ring gear. At this point, the direction of torque is changed from a horizontal to a vertical plane. The ring gear is bolted to the first stage sun gear. The sun gear, in turn, drives the first stage planet gears which mesh with a stationary ring gear.

The nonrotating ring gear causes the planet gears to revolve around the sun gear. The planet gears are attached to the first stage carrier which also revolves around the sun gear. The upper portion of the first stage carrier forms the second stage sun gear and it drives the second stage planet gears. These planet gears are attached to a second stage carrier and revolve in the same manner as the first stage planet gears and carrier.

Three stages of speed reduction take place during the transmission sequence resulting in an overall reduction ratio of 30.72 to 1 or a 66:1 ratio for the entire system.

In the forward transmission, the second stage carrier is bolted to the rotor shaft; in the aft transmission, the second stage carrier is splined to receive the aft rotary-wing drive shaft. The forward transmission rotor shaft is splined to receive the forward rotary-wing head. The aft rotary-wing (vertical) shaft is splined to receive the aft rotary-wing head.

The accessory gear box is mounted on the aft transmission. The transmission uses a quill shaft, which is splined into a sprag clutch to drive the accessory gears. The clutch permits the accessories to be driven by the apu-powered hydraulic motor, independent of the transmission whenever the main powerplants are not running.

The rotor tachometer generator is driven by the forward transmission. On recent series helicopters, an electric chip detector with cockpit warning light is provided. A magnetic plug is used on earlier versions.

The CH-47B transmissions are identical in principle of operation. However, some internal parts have been strengthened either by a change in design or by improved manufacturing processes so that they can accept the higher torque input.

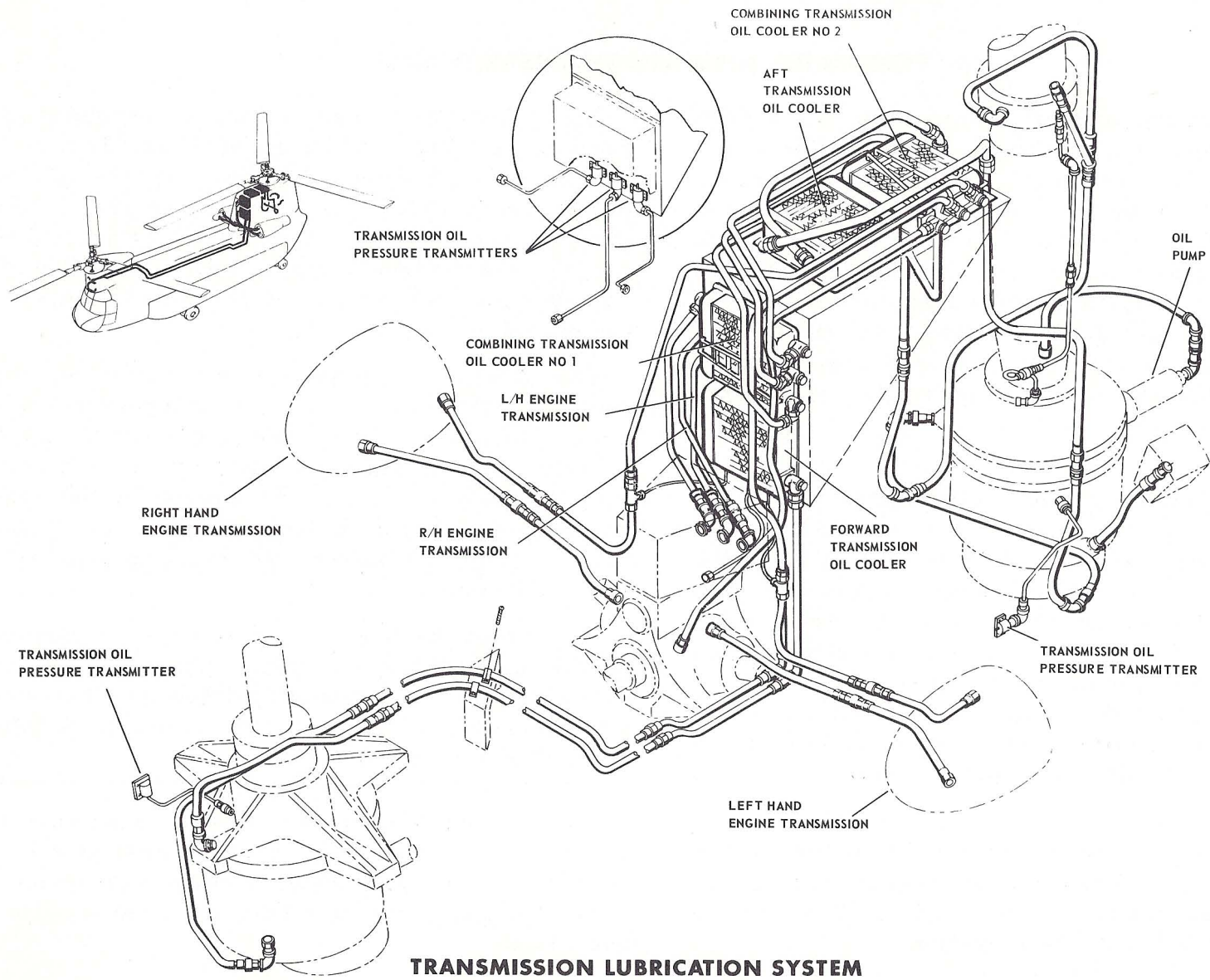

TRANSMISSION LUBRICATION SYSTEM



TRANSMISSION LUBRICATION

An individual lubrication system is provided for each transmission. A 6-element pressure/scavenge pump for the engine transmissions and the combining transmission is installed in the combining transmission below a 3-section tank.

The forward transmission oil pump is mounted on the bottom of the forward transmission; the aft transmission oil pump is mounted on the accessory gear box. Each of these pumps supplies oil to lubricating jets by way of internal passages in the respective transmission.

Four oil coolers are located in the pylon. Two coolers, composed of three sections, are for the two engine transmissions and the combining transmission. They are connected in series and oil flow is continuous through both of them. The other two coolers are for the forward and aft transmissions. Air is drawn through these coolers by a fan which is driven by the aft transmission.

A transmission oil pressure indicator and a selector switch are mounted on the instrument panel. Depending on the position of the selector switch, the lowest oil pressure of all the transmissions or the actual oil pressure of each transmission will be shown on the indicator.

Transmission oil temperature is indicated in the same manner as the pressure. The indicator shows either the highest temperature present or the temperature of the oil in one selected transmission.

Two caution lights, one for pressure and one for temperature, are located on the console.

Each transmission contains a magnetic chip detector with a remote reading circuit. An accumulation of metal particles across the gap in the chip detector plug completes an electrical circuit and illuminates a warning light on the auxiliary master caution panel in the cockpit.

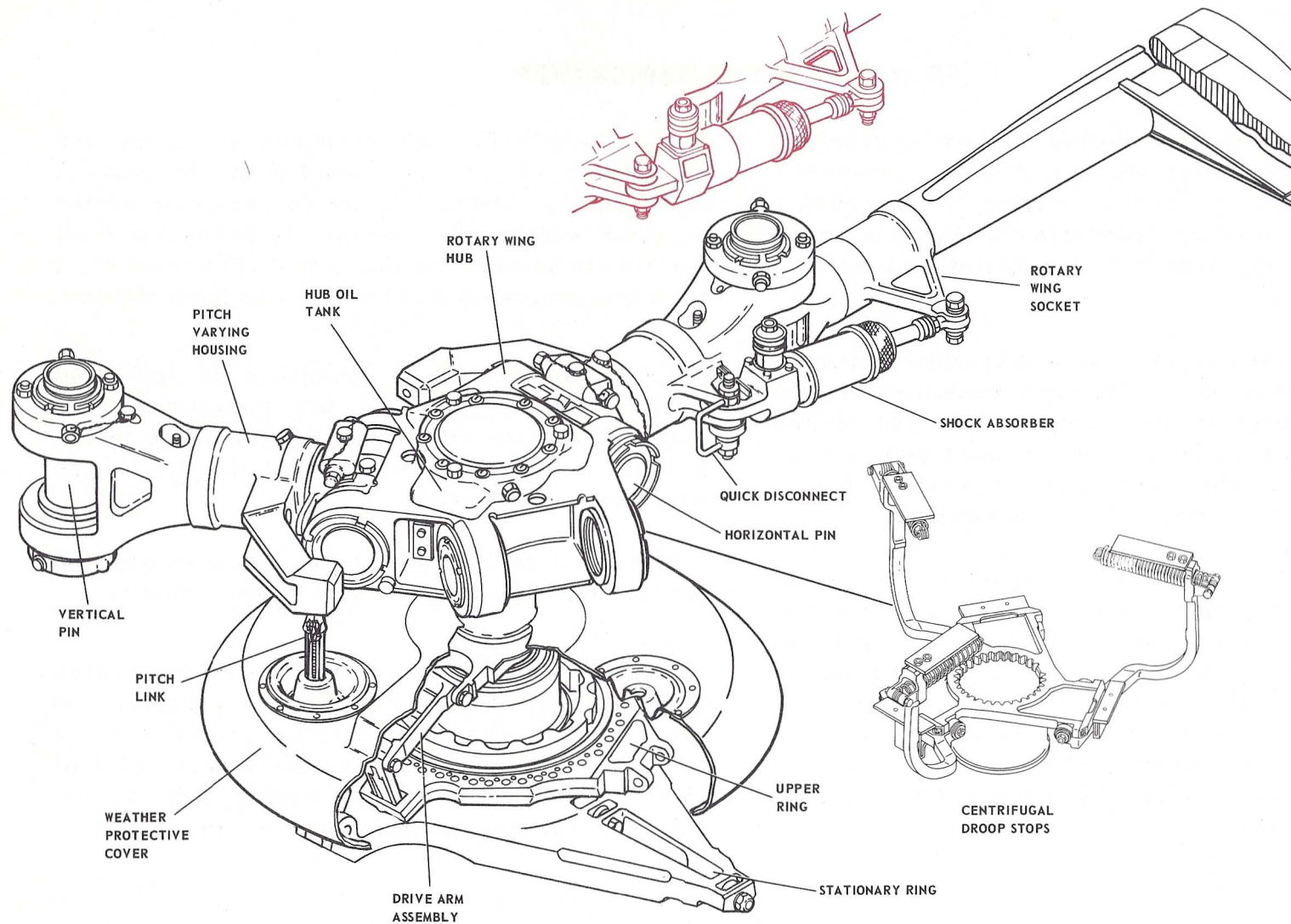

ROTARY-WING ASSEMBLY



ROTARY-WING HEADS

The rotary-wing heads, splined to the respective vertical shaft, receive torque from the forward and aft transmissions and, in turn, drive the rotary-wing blades. The heads are secured to the shafts by nuts.

Each head consists of a hub with three pitch-varying shafts attached to it by horizontal hinge pins. These pins permit blade flapping. On the earlier series of helicopters, both heads utilized static droop stops attached to the top and bottom of the shafts to limit blade flap and droop. On the later series of helicopters, a centrifugal droop stop mechanism has been installed at the aft rotary-wing head. Centrifugal force acting on balancing arms at high rpm causes the interposer blocks to move out from between the hub and pitch-varying shaft. At low rpm, the springs override the centrifugal force and position the interposer blocks between the hub and pitch-varying shaft, thus reducing the blade droop angle which, in turn, reduces the possibility of droop stop pounding.

Mounted coaxially over the pitch-varying shafts are pitch-varying housings to which the blades are attached by vertical hinge pins. These pins permit leading and lagging movements of the blades. Direct-action shock

absorbers, connected between the blade assemblies and pitch-varying housings, limits the blade lead and lag motions.

The shock absorbers are attached to the pitch-varying housings by quick-disconnect fittings. Each pitch-varying housing is internally connected to the pitch-varying shaft by a laminated steel tie bar. The laminated tie bar allows the pitch-varying housing to be rotated on the shaft, thus changing the blade pitch, while retaining the housing on the pitch-varying shaft. An oil lubrication system, consists of an oil tank for the horizontal-pin bearings and individual oil tanks for the pitch-varying bearings and the vertical-pin bearings. A plastic sight cup, located on the outboard underside of the pitch-varying housing, functions as an indicator of oil leakage past the pitch shaft oil seal.

The CH-47B rotary-wing heads retain the same basic configuration, but certain design changes have been incorporated to accommodate the droop snoot blades and other refinements based on operating experience. The changes include: new vertical and horizontal pin bearings, strengthened vertical pins to accept the greater weight of the blades, and strengthened pitch arms and pitch housings. The shock absorber quick-disconnect fittings have been replaced by a bolt connection and the plastic sight cups have been eliminated.

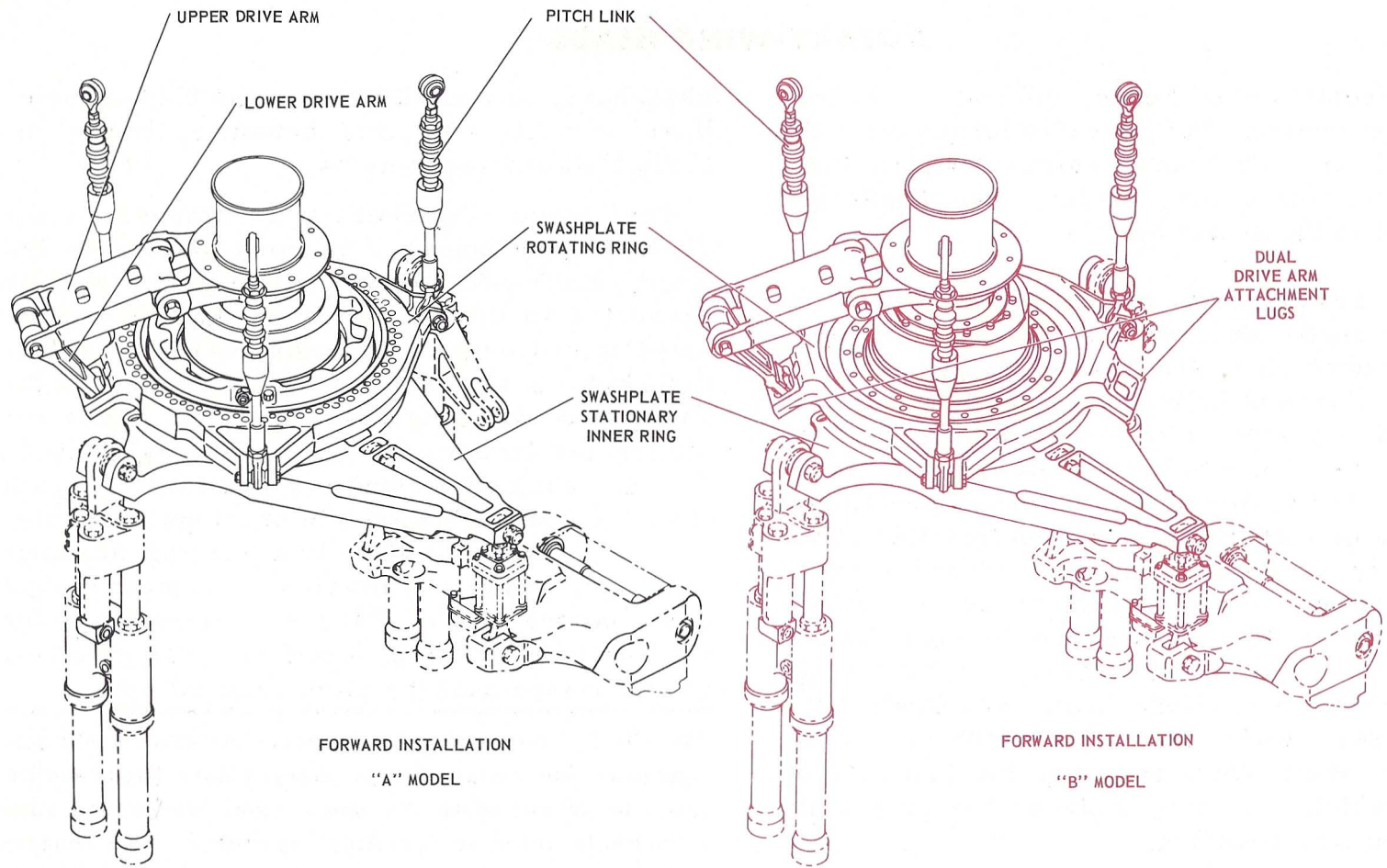

ROTARY-WING CONTROLS



ROTARY-WING CONTROLS

The rotary-wing controls are located around each rotary-wing head drive shaft, between the pivoting and swiveling actuators and the rotary-wing head. The forward and aft controls are similar except for differences required by the direction of rotary-wing head rotation. The controls for each rotary-wing system consist of three pitch links, a controllable swashplate, a drive-arm assembly, and a drive collar which is splined to the rotary-wing head drive shaft. The controllable swashplate consists of a stationary inner ring, a ball bearing, and an outer rotating ring. Both rings are assembled on a convex, or ball shaped, inner sliding ring called a ball spherical bearing.

The ball spherical bearing moves in a vertical plane on the slider shaft, thus providing vertical movement of the swashplate. Tilting movements occur on the convex surface of the ball. The hinged drive-arm assembly, which is bolted to the collar, provides rotational force to the swashplate outer ring. Movements of the pivoting and swiveling actuators are directed to the swashplate stationary ring which transmits the force to the swashplate outer ring. Pitch links, attached to the rotating ring, transmit the force

to the pitch-varying housings on the rotary-wing head. The pitch links are adjustable and control the blade tip path plane. Flight control movement, manual or automatic, results in vertical or tilting movement of the swashplate. Movement of the swashplate results in a corresponding movement of the blade plane.

The swashplate is lubricated by either of two methods: the original design uses an oil tank mounted on the swashplate to supply oil to the ball bearing; the later configuration is grease-lubricated through a single grease fitting. Dry teflon bearings are used on the ball spherical bearing.

A weather-protective cover is installed over the rotary-wing controls. The cover is bolted to, and rotates with, the drive collar. Water tight boots seal the openings in the cover through which the pitch links pass.

The CH-47B rotary-wing controls incorporate strengthened pitch links and a strengthened rotating ring which permits an increase in the input loads. The rotating ring also has dual drive arm attachment lugs which allows interchangeability of a swashplate assembly between the forward and aft locations.

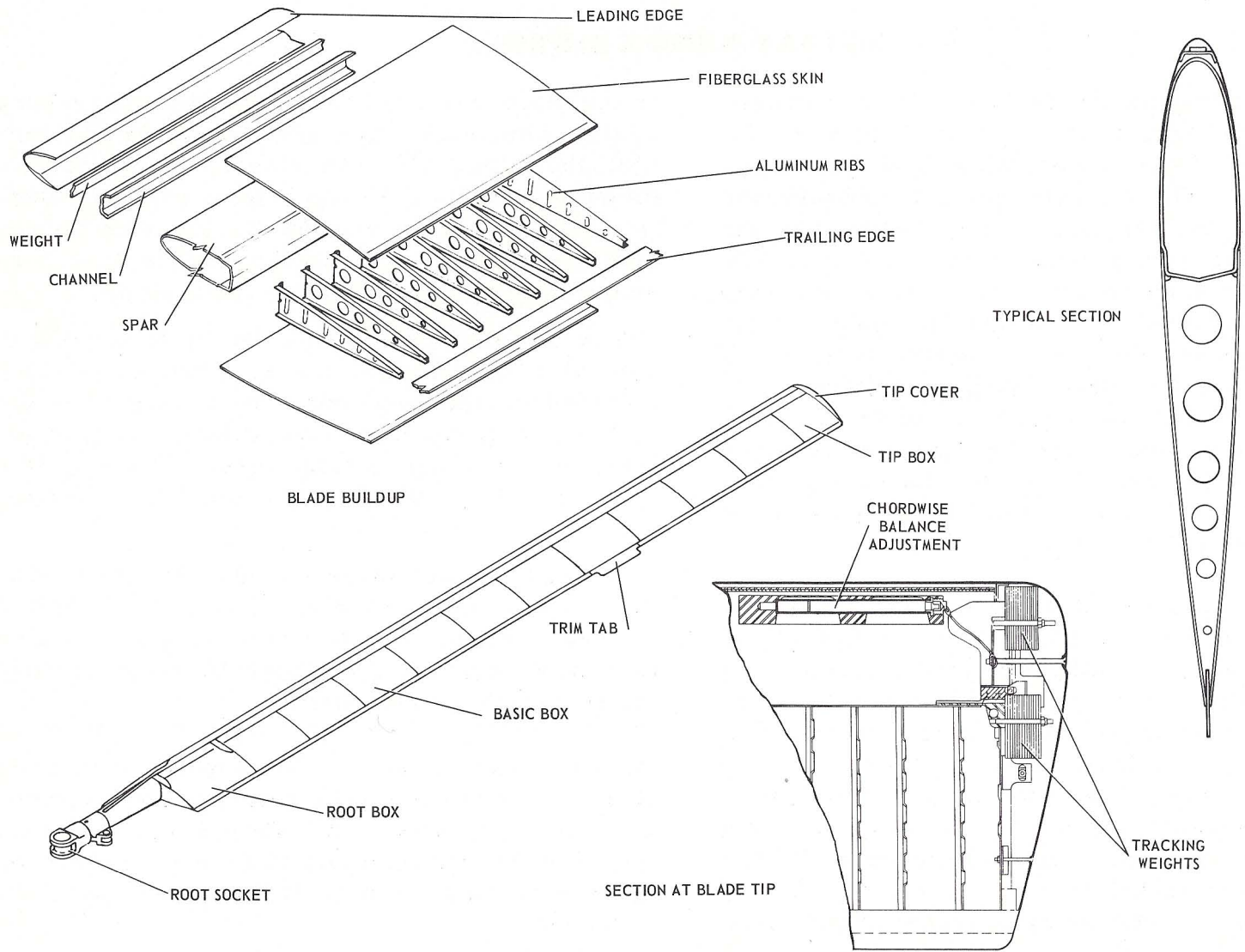

ROTARY WING

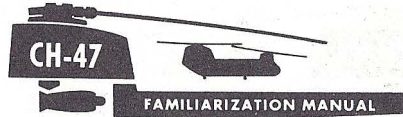

ROTARY-WING BLADES

Each rotary-wing blade assembly consists of a D-spar, an attachment socket, a nose cap assembly, trailing edge strip, tip balance provisions, and a tip cover. Three interchangeable blade assemblies are installed on each rotary-wing head.

The steel D-spar is circular at the root end and threaded to receive the attachment socket.

The attachment socket is slotted and threaded and is screwed onto the threaded root end of the spar. The socket is then clamped by a bolt installed through lugs formed on either side of the slots in the socket. A special bolt is installed through the socket and the spar to maintain the preset angular alignment or angle of incidence of the two parts. The socket also forms integral mounting lugs for attachment of a direct-action shock absorber.

The blade leading edge is a formed stainless steel nose cap with a balance weight assembly

bonded internally to it. The leading edge is then bonded to the D-spar. Individual box fairings, consisting of external skins, bonded to airfoil-shaped aluminum ribs, are in turn bonded to the trailing edge of the D-spar. A trailing edge is formed by bonding a full-length, laminated stainless steel strip between the upper and lower skins of the fairing at the aft end.

Movable tracking and balance weights are installed on stainless steel fittings which are riveted to the tip of the D-spar. These weights are used for making balancing and tracking corrections at the factory.

To provide interchangeability, all rotary-wing blades are balanced and tracked to master blades at the factory. A removable tip cover provides access to the weights. A tie-down fitting socket is located on the bottom surface of each rotary-wing blade assembly near the tip.

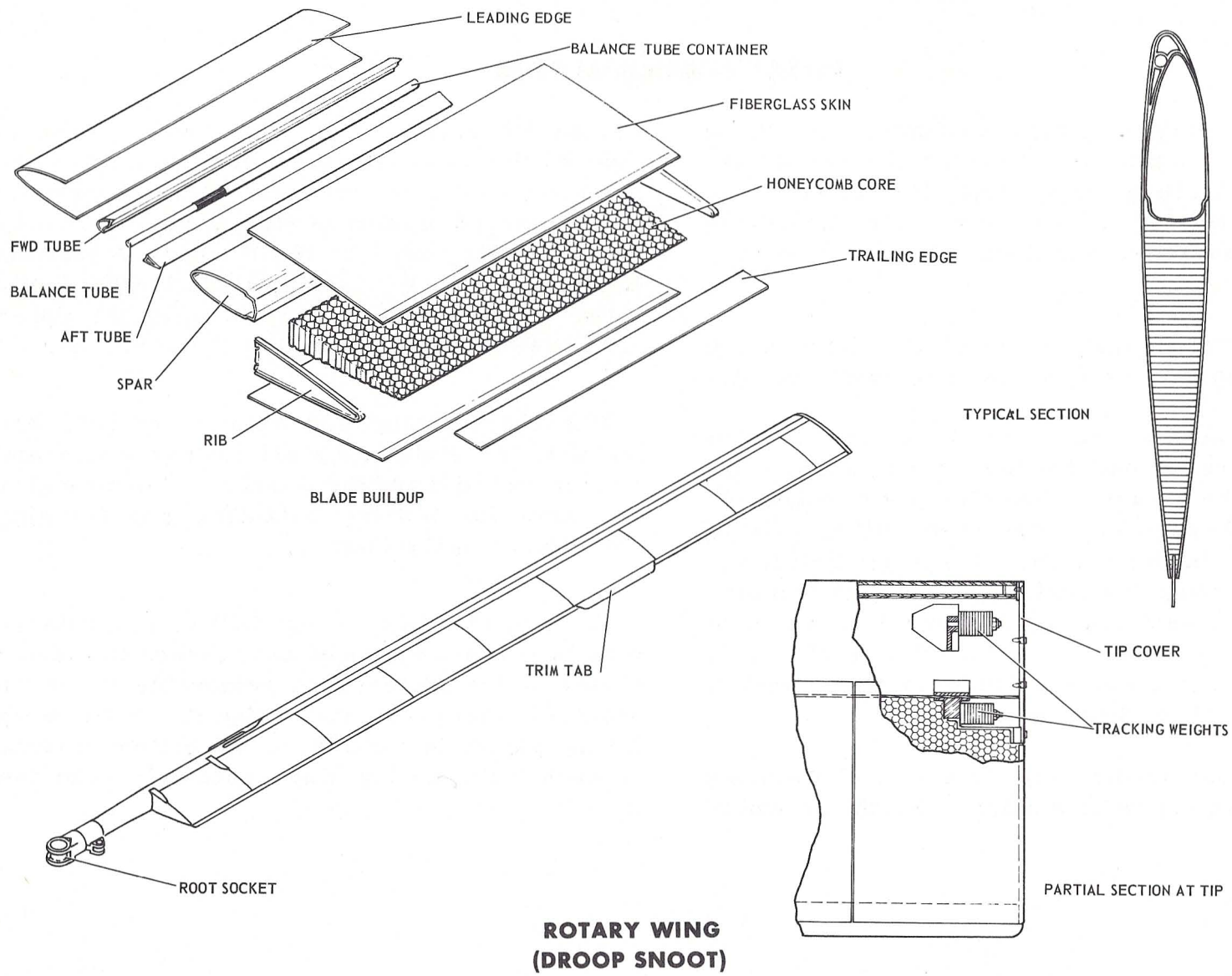



ROTARY-WING BLADES (DROOP SNOOT)

Droop snoot (non-symmetrical) rotary-wing blades are installed on the CH-47B helicopter. The non-symmetrical airfoil provides increased blade lift capability and permits a greater flight speed. The droop snoot blade is less sensitive to rotor stall in gusts and maneuvers due to its increased lift capability.

Construction of the droop snoot blade is similar to that of the symmetrical blade. The leading edge is a formed stainless steel nose cap with three additional tubes bonded to it and the D-spar. Two of the tubes are contoured to the airfoil while the third is cylindrical in shape. The forward inner tube is a provision for chemical anti-icing while the cylindrical tube serves as a container for spanwise balance weights. The aft tube serves as a spacer and support for the cylindrical tube.

The fairings (blade boxes) are formed from aluminum honeycomb and covered with fiberglass skin. Nine fairings make up the rotary-wing assembly. Each fairing assembly is bonded to the D-spar and plastic ribs are bonded to each side of the assembly. A laminated stainless steel trailing edge strip is bonded to the fairing assemblies along the full length of the blade. A trim tab is bonded to the trailing edge.

Tracking and balance weight plates are attached to a fitting at the D-spar tip. The weight required is determined at the factory or at overhaul and is not field adjustable. Since the blades are tracked to master blades at the factory, they are interchangeable, but only on the same (forward or aft) rotary-wing head. A tie-down fitting socket is located on the bottom surface of the blade near the tip.

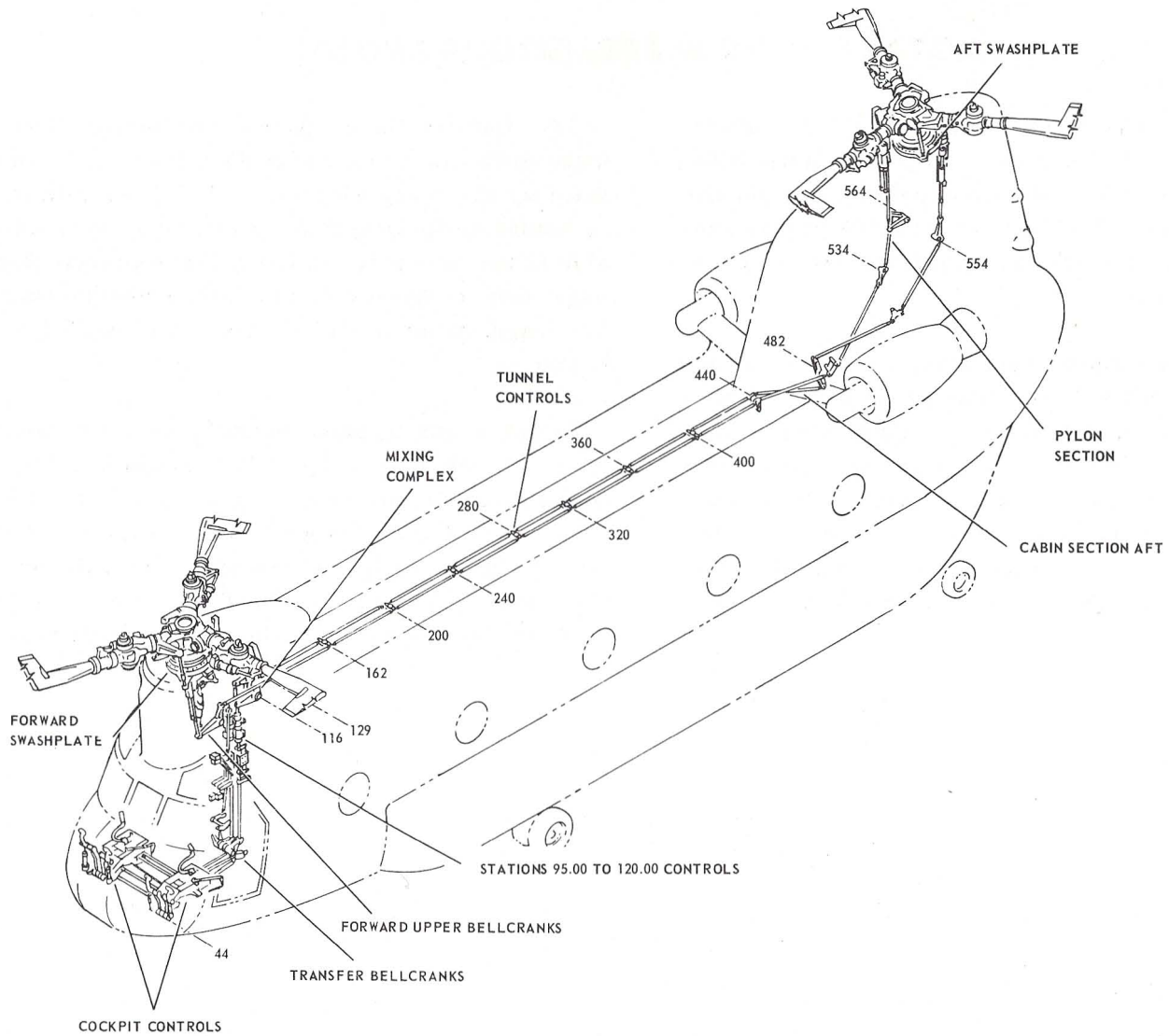

FLIGHT CONTROL SYSTEM SCHEMATIC



FLIGHT CONTROLS

The flight control system of the CH-47 is composed of two power boost systems, two electronic stabilization systems and a linkage system, which mixes and transmits control motions from the cockpit controls to the rotor heads. The linkage is divided into six main sections: Cockpit flight controls, flight controls between stations 95.00 and 120.00, flight control mixing, forward upper flight controls, flight controls within the tunnel, and aft flight controls.

The pilot and copilot each have a separate set of cockpit controls, interconnected beneath the cockpit flooring. Movement of either set of cockpit controls results in a corresponding movement by the other set. Each cockpit control assembly contains a pitch and roll control stick, a thrust control, and directional pedals. Control movements initiated by either the pilot or the copilot are directed from the cockpit control assemblies to the vertical controls between stations 95.00 and 120.00.

Also contained within this section of the flight controls the dual stick-boost actuating cylinders which supply hydraulic assist for the cockpit flight controls, Stability Augmentation System (SAS), a differential collective-pitch (DCP) speed and stick trim actuator, spring assemblies and

magnetic brakes. The spring assemblies and magnetic brakes provide artificial feel to the cockpit control assemblies; normal feel is lost due to the hydraulic assist provided by the dual stick-boost actuating cylinders. The dual extensible links function as variable-length links, controlled by signals from the SAS, or as fixed links if the SAS is not operating.

Thrust, pitch, yaw, and roll control motions are directed to the mixing units where the four motions are combined to produce two integrated movements which are transmitted to the upper controls. The resulting control motions are transmitted to the forward upper controls directly and transmitted to the aft upper controls by means of the linkages in the tunnel fairing.

Pivoting and swiveling dual actuating cylinders are installed in both the forward and aft upper controls. These cylinders are connected between the helicopter structure and the controllable swashplates. Control motion to the cylinders operate control valves which direct hydraulic power to extend or retract the cylinders. The cylinders, in turn, move the swashplates in corresponding directions. Longitudinal cyclic trim actuators which are part of the speed trim system are also connected to the swashplates.

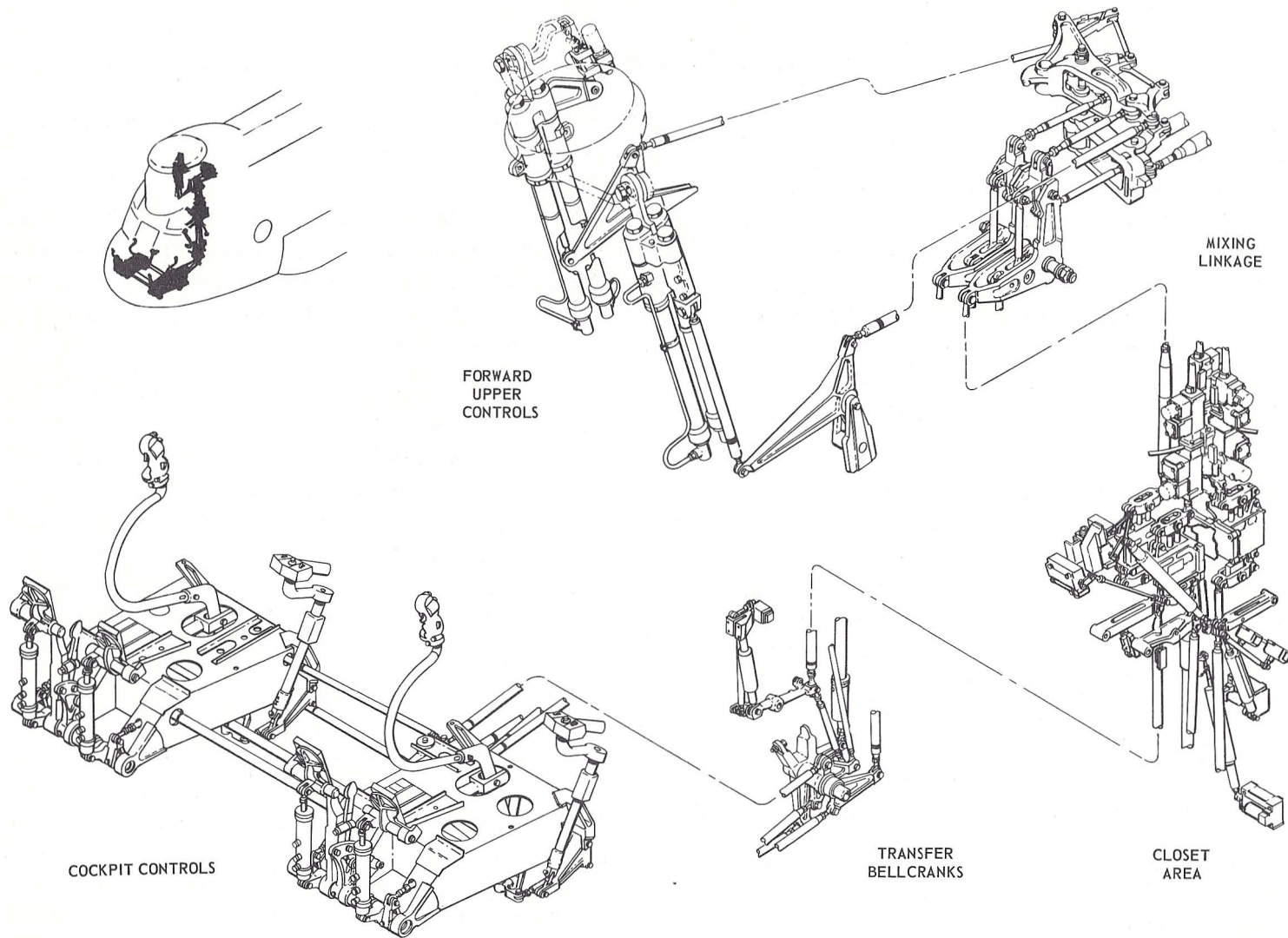

FLIGHT CONTROLS COMPONENTS

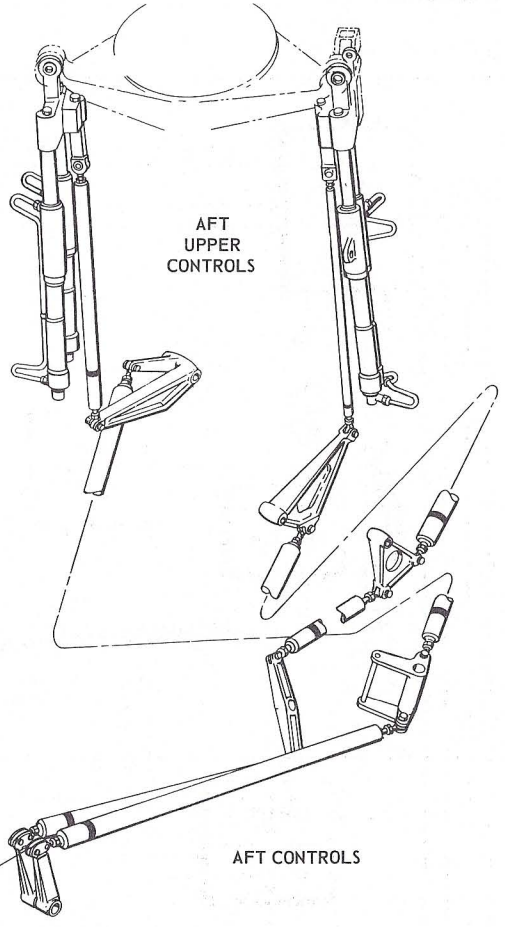
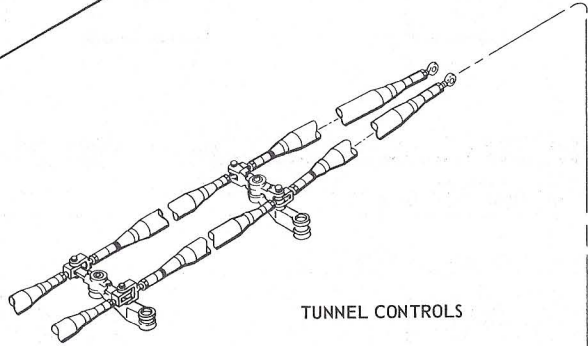
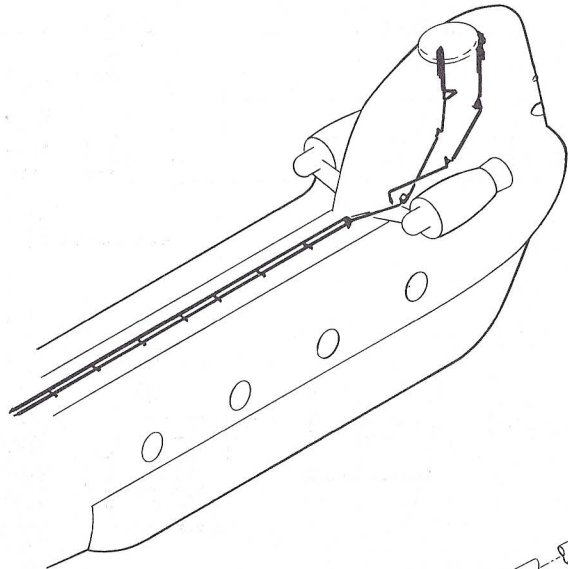

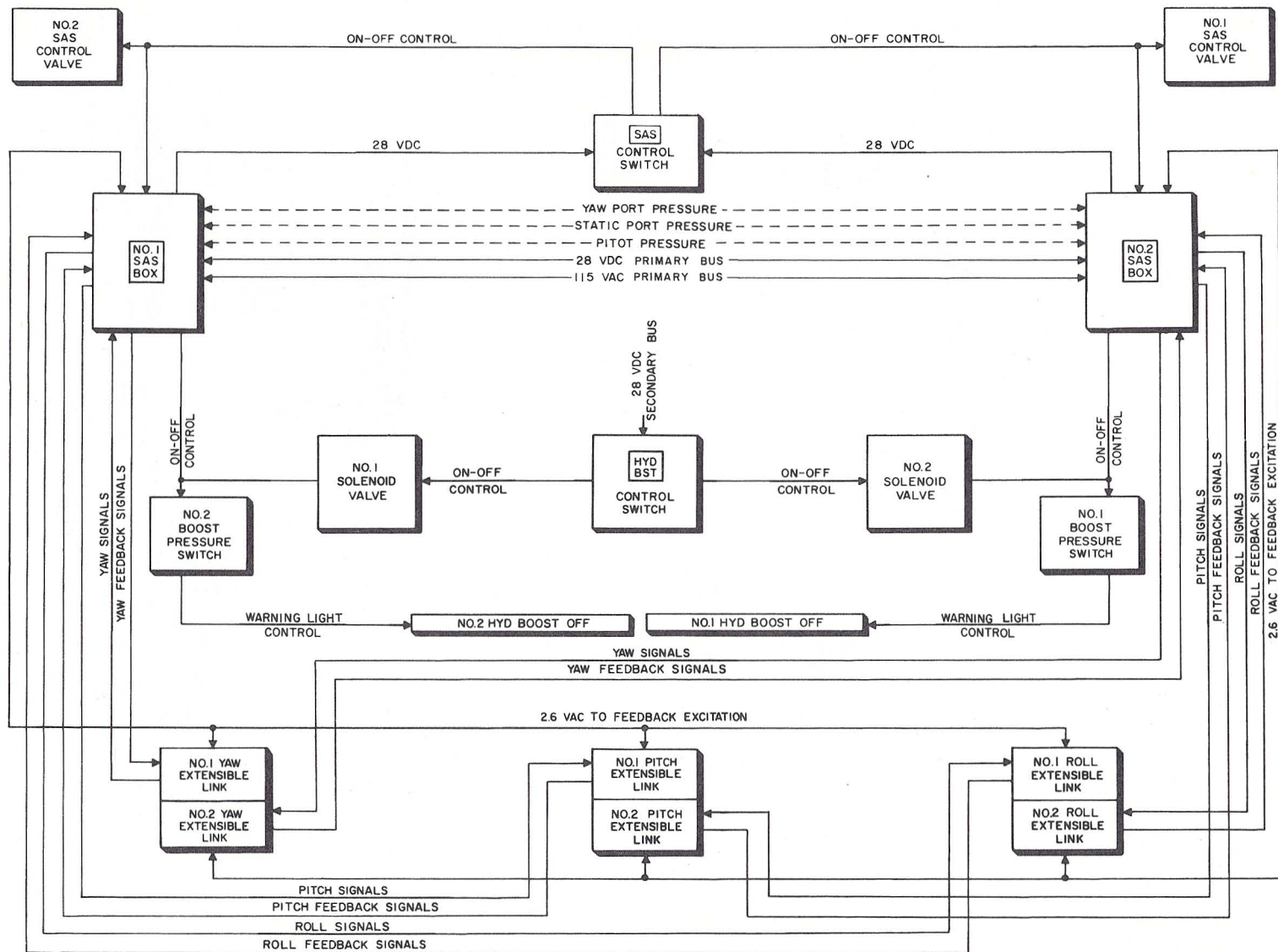

BLOCK DIAGRAM - SAS SYSTEM



STABILITY AUGMENTATION SYSTEM

The Stability Augmentation System (SAS) is an electronic rate sensing system which maintains helicopter stability about the roll, pitch, and yaw axes through independent positioning of the flight controls. This eliminates the small corrective movements normally required by the pilot to keep the helicopter at the desired attitude. In performing its rate damping function, the SAS senses any abrupt movement of the helicopter and immediately reacts to offset it. This instantaneous corrective reaction tends to dampen any sudden motion or change of attitude. The SAS has limited authority (less than 50 percent) and will induce corrective action to the flight controls up to that point. Any corrective action beyond this limit must be induced by the pilot. The pilot retains full control of the helicopter and can override the SAS if he desires.

A rate gyro, sensing a change in the helicopter attitude, produces a signal which is amplified and sent to its respective extensible link, causing it to extend or retract, which repositions the rotary-wing controls to counteract the initial change in helicopter attitude. All this action takes place without any movement of the cockpit controls.

To ensure complete reliability, two identical stability augmentation systems are installed so that no power failure to one electronic amplifier or hydraulic supply system can cause a loss of stability augmentation which cannot be recovered by transferring to the alternate system. The dual system is designed so that either SAS can be used independently or the two systems can be used together; in the latter case, each system operates at half gain. When both systems are in use, a single power failure will be of little consequence to the pilot since the operational SAS will automatically switch to full gain and thereby continue to stabilize the helicopter.

Each SAS amplifier contains the rate gyros, channel amplifiers, and circuitry necessary for the operation of that system in controlling roll, pitch, and yaw axes. In addition, each SAS amplifier contains internal test circuits which allow the checking of each channel (pitch, roll and yaw) and thus eliminates the necessity of using outside test equipment.

Sideslipping of the helicopter is sensed from ports on the forward fuselage. Differential sideslip pressure is converted to an electrical signal in the SAS amplifier and directed to the yaw extensible link for sideslip corrections.

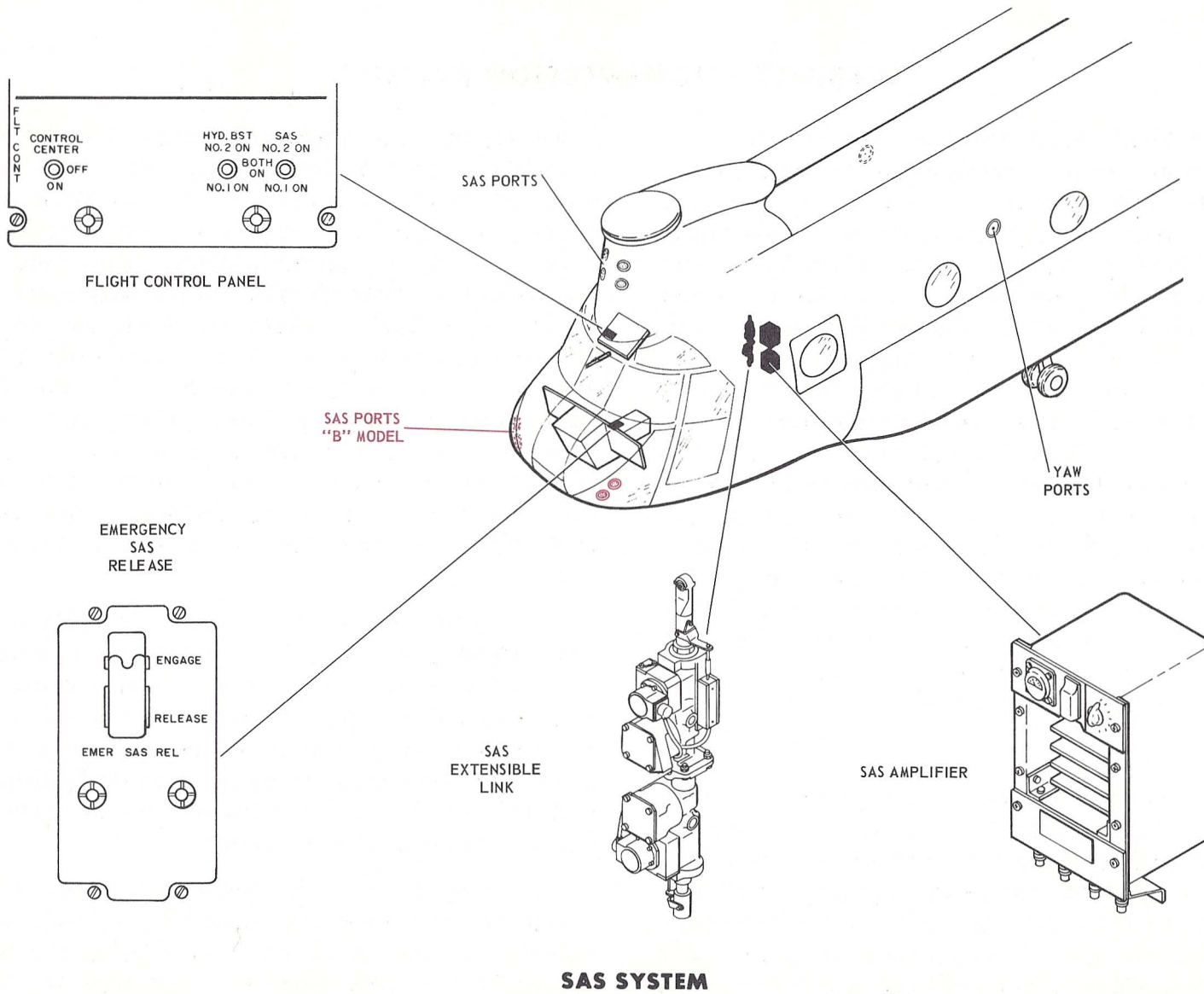

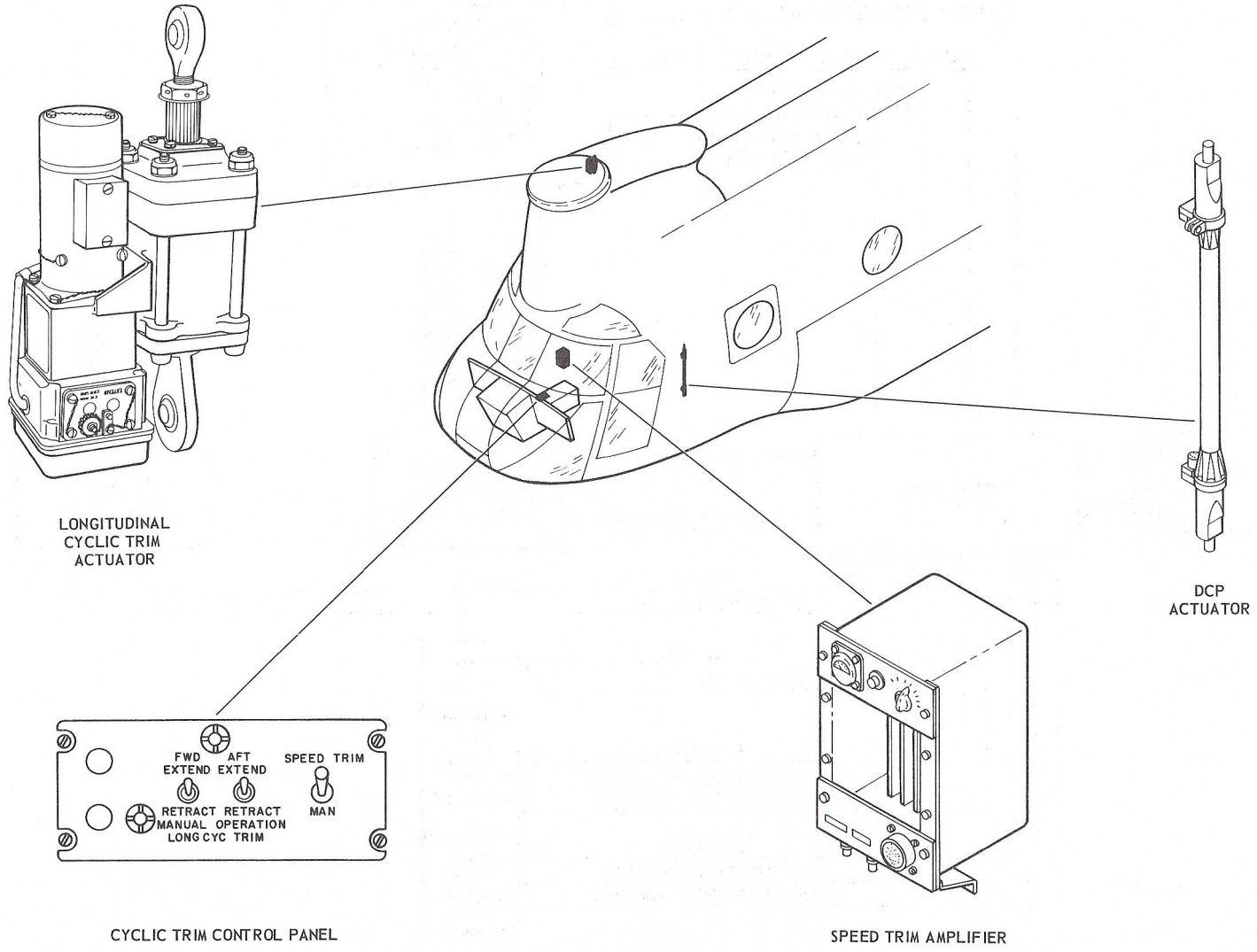

SPEED TRIM SYSTEM

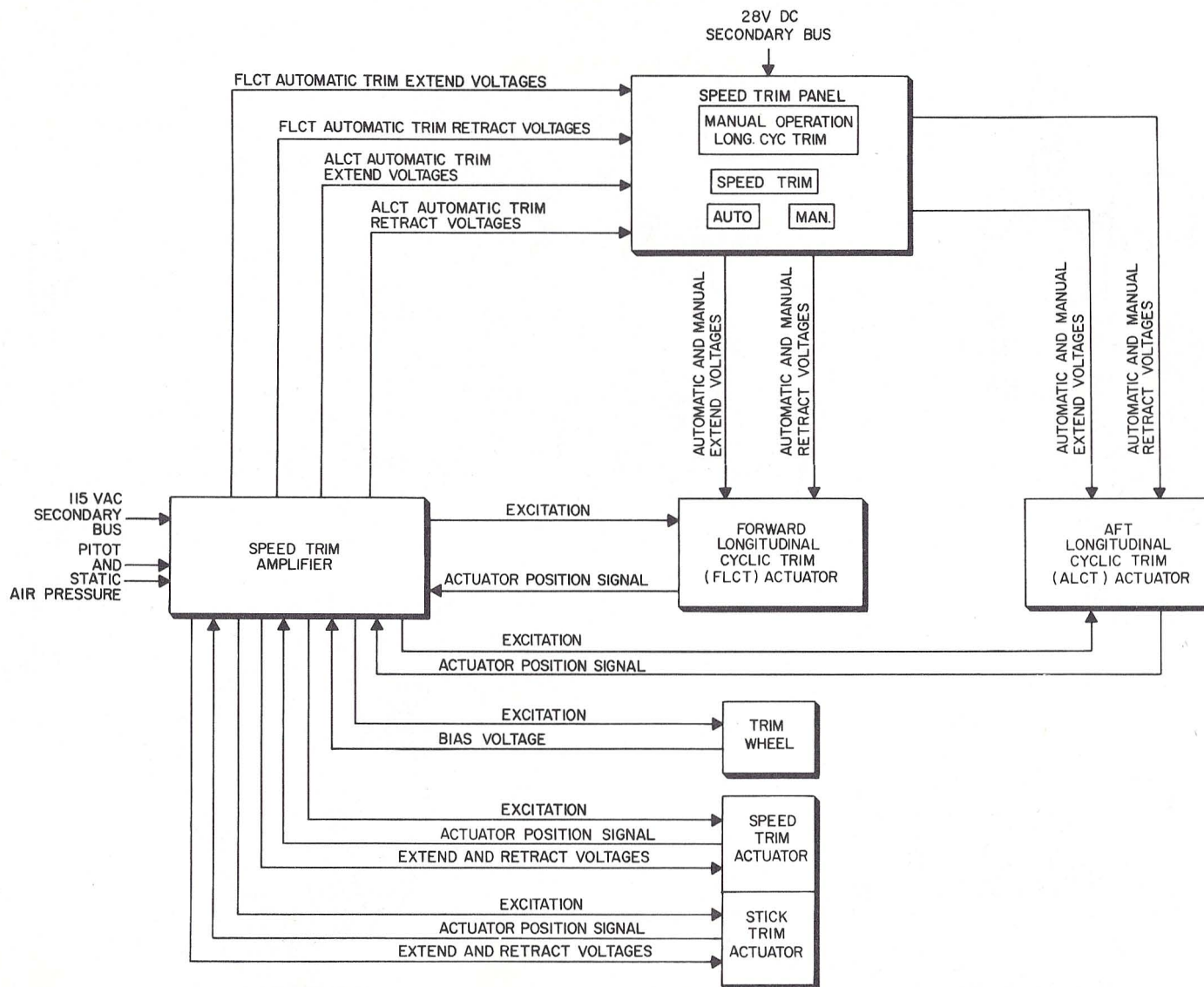

BLOCK DIAGRAM - SPEED TRIM SYSTEM



SPEED TRIM SYSTEM

The Speed Trim is an electronic arrangement which maintains a level fuselage over a wide range of forward airspeeds while providing positive stick gradient. It also allows the pilot to maintain a comfortable stick position during adverse center of gravity conditions.

The system converts airspeed information from the pitot-static system to an electrical signal which controls electromechanical actuators in the flight control system. The actuators vary the differential collective pitch of the blades and the plane of rotation of the rotary-wing heads. The pilot controls the mode of operation (manual or automatic) through the use of selector switches.

A stick trim wheel in the cockpit serves to electrically re-rig the control system and reposition the cyclic stick to maintain a neutral longitudinal position.

The longitudinal cyclic trim actuators, one at each upper rotor control assembly, convert electrical signals to mechanical movement to change the angle of attack or attitude of the blades. Two cyclic indicators are included in the cockpit instrumentation to display the position of these actuators.

The DCP actuator is located in the flight controls compartment between stations 95.00 and 120.00, and consists of two independent actuators connected by an aluminum tube. The upper actuator is controlled electrically by the speed trim amplifier to program corrective motion to the flight controls in order to maintain a positive stick gradient.

The lower actuator is controlled electrically by the trim wheel. It re-rigs the flight controls pitch system to maintain a comfortable stick position.

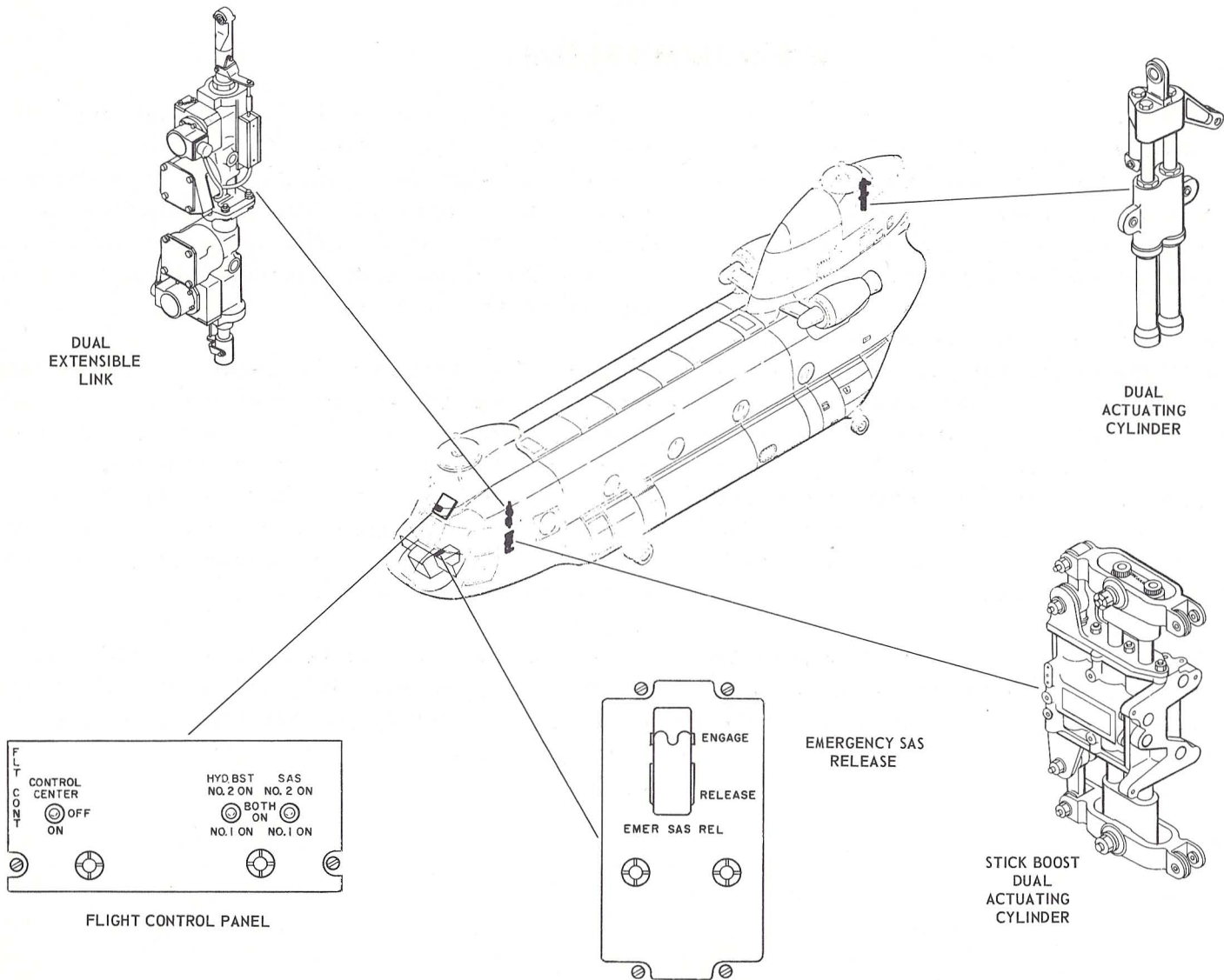

FLIGHT CONTROL HYDRAULIC SYSTEM



FLIGHT CONTROL HYDRAULIC SYSTEM

The flight control hydraulic system consists of two identical but independent systems: flight control system No. 1 and flight control system No. 2. Each system contains its own hydraulic tank, pump, and plumbing installation, along with the necessary valves, filters, and fittings that are required to complete the system. Each system supplies hydraulic pressure to operate the forward and aft pivoting and swiveling dual actuating-cylinders, the Stability Augmentation System (SAS) dual extensible links, and the dual stick-boost actuators.

In each system, hydraulic fluid from the tank is gravity fed to the pump where the fluid is pressurized to 3,000 psi and then is directed to the flight control manifold. In the manifold, fluid passes through a filter to a pressure relief valve and a solenoid-operated control valve. Fluid from the manifold is directed to the aft pivoting and swiveling dual actuating-cylinders and through a filter to the forward swiveling and pivoting dual actuating-cylinders. At the same time it is directed to a 1,500 psi pressure reducer. The reduced pressure is directed through a filter to the SAS solenoid

control valves and, at the same time, to the dual stick-boost actuating-cylinder manifolds where passages direct the fluid to the actuating-cylinders. When either No. 1 or No. 2 SAS is selected, the related SAS solenoid control valve is open and the fluid is directed to the dual extensible links; if BOTH is selected, both control valves are open. The fluid is returned from the dual actuating-cylinders through a filter to the hydraulic tank. The pivoting and swiveling dual actuating-cylinders and the dual stick-boost actuators are capable of normal operation even when powered by only one hydraulic system. The dual extensible links consist of two actuators which are bolted together, end to end. The No. 1 hydraulic system supplies fluid to the lower actuators of the dual extensible links and the No. 2 system supplies fluid to the upper actuators. When both hydraulic systems are functioning, each actuator of a dual extensible link provides one-half of the total motion required. If one hydraulic system fails, the affected actuator locks in a fixed dimension. The other actuator will then automatically provide the full motion required.



FLIGHT PRINCIPLES

The helicopter differs from the fixed-wing aircraft in that its lifting surfaces rotate. In the CH-47, lift and propulsion are derived from two rotary-wing heads each with three blades, one located forward and the other aft. Since these heads rotate in opposite direction, torque is cancelled out, and no anti-torque rotor is required. The CH-47 blade cycle illustrates how a fully articulated rotary-wing system maintains symmetric lift. In forward flight dissymmetry of lift is caused by the relative wind, which acts as a head wind on the advancing blade and increases the lift, while it acts as a tail wind on a retreating blade and decreases the lift.

To equalize the lift throughout the cycle, the blades are permitted to flap. The advancing blade flaps upward because of increased lift; the retreating blade flaps downward because of decreased lift. The resulting relative wind causes a reduction in angle of attack of the advancing blade and an increase in angle of attack of the retreating blade. In this way lift is equalized across the rotary-wing disk.

The cycle of a single forward blade with counterclockwise rotation is illustrated. The same cycle occurs with the aft blade, except that rotation is clockwise which reverses the 90° and 270° positions in the cycle.

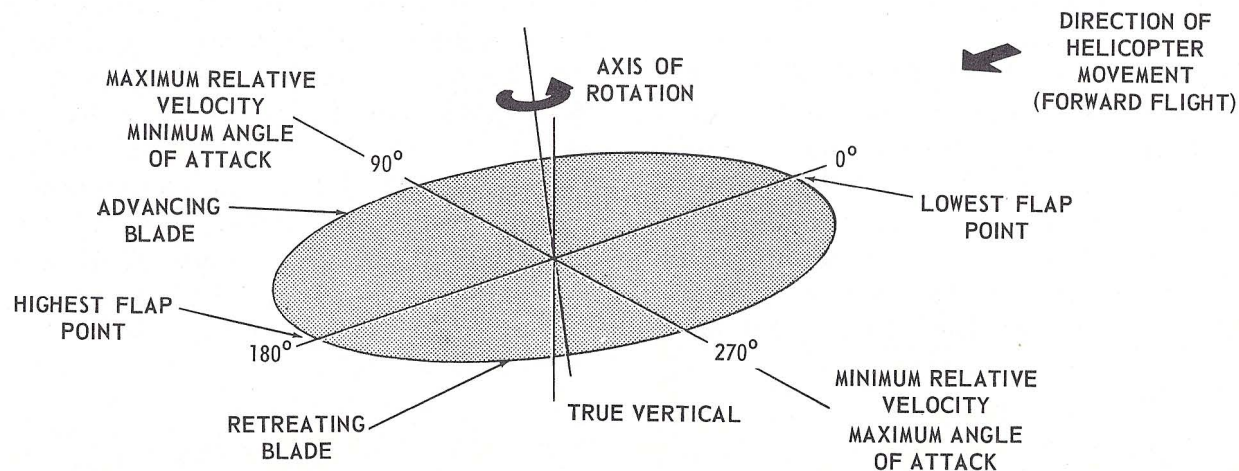

Hinge Points

A fully articulated blade assembly is capable of movement in three directions about its attachment to the rotary-wing head: up and down (flap) through a horizontal hinge pin, side to side (lead and lag) through a vertical hinge pin, and rotating (to increase or decrease pitch) through the laminated tie bars within the pitch-varying housing to which the blade assembly is attached.

Lead-lag movements and flapping are caused by external aerodynamic forces prevailing in the rotary-wing plane of rotation and are beyond the pilot's control. Pitch changes are controlled by the pilot, either collectively to vary the lift or cyclically to vary the flight direction.

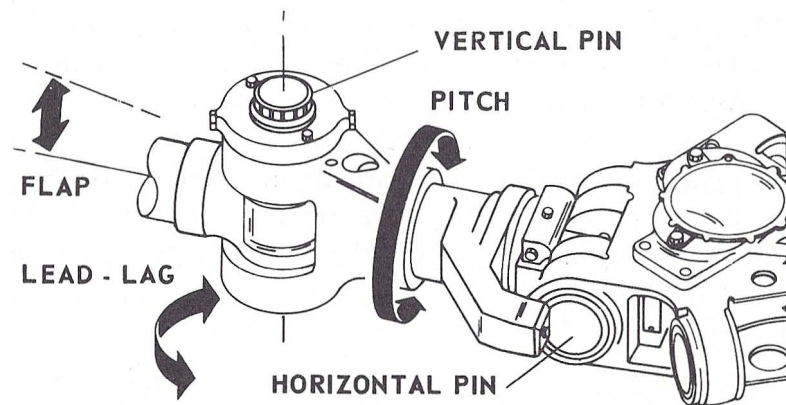

Control Actions

The CH-47 has three basic pilot flight controls: directional pedals, pitch and roll control stick, and thrust control. The first two controls are positioned similarly to those in fixed-wing aircraft, while the latter is located to the left of each pilot's seat. A brief explanation of the helicopter control actions follows.

Flight control movements are transmitted through a system of bellcranks, push-pull tubes, and a mixing unit. Control movements are mixed to become lateral cyclic and collective pitch motions to the hydraulic actuators in the upper controls.

These controls tilt swashplates in the rotary-wing controls, which, in turn, raise or lower pitch links. The pitch links vary the pitch of the rotary-wing blades during the rotation cycle.

Coordination of controls to produce various flight maneuvers is customary, as in fixed-wing aircraft. However, it must be remembered that helicopter control actions have their own characteristic effects on aircraft attitude, and that an additional control, the thrust control, must be coordinated for certain maneuvers. A climbing turn, for instance, is accomplished by use of directional pedal, aft control stick, and increased thrust.

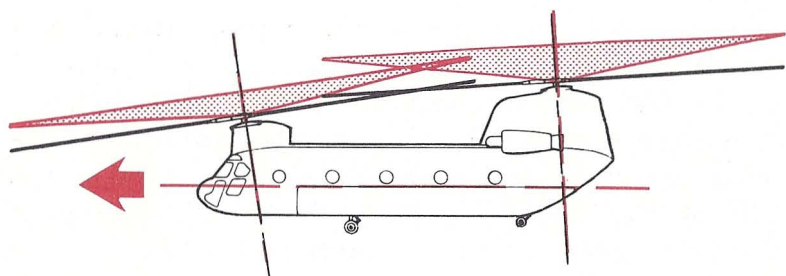

Control Stick (Stick Forward Shown)

For forward flight, the pilot moves the control stick forward; the thrust of the aft rotary wing is increased while the thrust of the forward rotary wing is decreased, causing the helicopter to move forward. Since there is a large range of longitudinal control, high forward speed and extremes in center-of-gravity travel are inherent.

When the pilot wishes to move laterally or to roll to the left or right, he moves the control stick in the desired direction; this action tilts the plane of rotation of both rotary wings in the same direction, causing a corresponding movement of the helicopter.

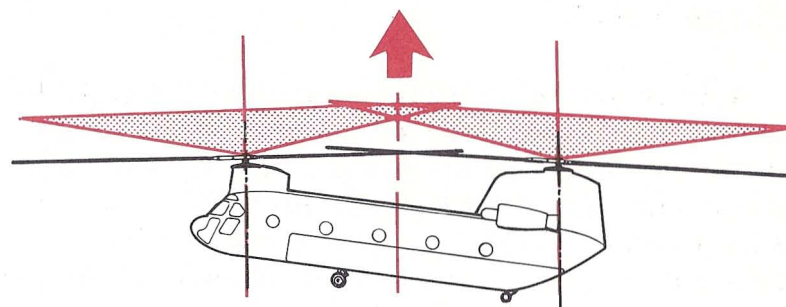

Thrust Control (Increased Thrust Shown)

To produce climbs or descents, lift can be varied by changing the thrust of the rotary wings. When the thrust control in the cockpit is raised, the pitch of all six rotary-wing blades is increased simultaneously and causes the helicopter to ascend. Lowering the thrust control decreases the pitch of all six rotary-wing blades, causing the helicopter to descend. An intermediate setting of the thrust control permits a desired altitude to be maintained.

Autorotation is accomplished, without engine power, by lowering the thrust control and maintaining slight forward motion to the landing site.

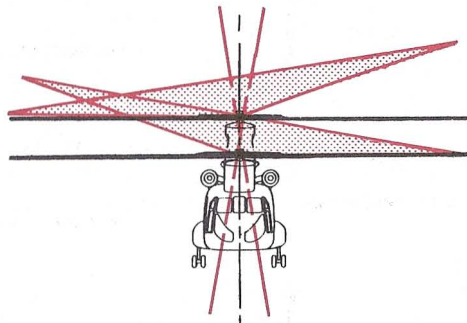

Directional Control (Left Pedal Application Shown)

Directional control is achieved by tilting the plane of rotation of the rotary wings. Control motions to accomplish this are imparted by the control stick or the directional pedals, or both.

Since the lift of the rotary-wing blades is increased through part of the cycle and decreased through another part of the cycle, the plane of rotation is tilted. As the rotation plane tilts, the helicopter moves in the direction of the downward side of the tilt.

When the pilot applies directional pedal movement in one direction, the plane of rotation of the forward rotary wing is tilted downward in the same direction; simultaneously, the plane of rotation of the aft rotary wing is tilted downward in the opposite direction. The result is a hovering turn around the vertical axis.

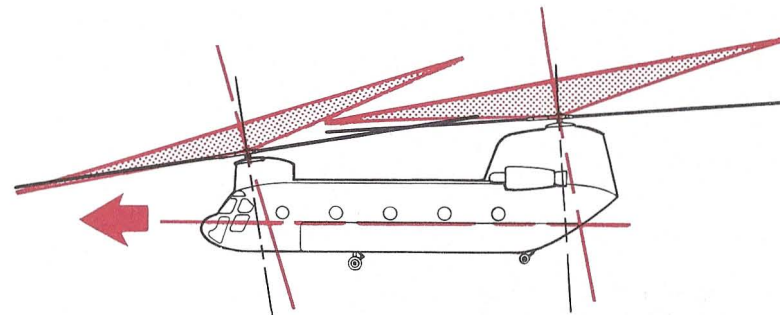

Automatic Speed Trim

Increasing air speed creates an electronic signal in the automatic speed trim system to provide longitudinal cyclic tilt of the rotary wings. This system automatically adjusts the tilt of both rotary wings to a substantially level fuselage attitude at high speed. Increasing air speed also provides programmed removal of some differential collective pitch induced with the control stick, thereby providing a positive stick gradient.

If airspeed is constant and the helicopter is momentarily displaced longitudinally by gusty winds causing an airspeed change, the speed trim system will tend to return the helicopter to the selected speed.

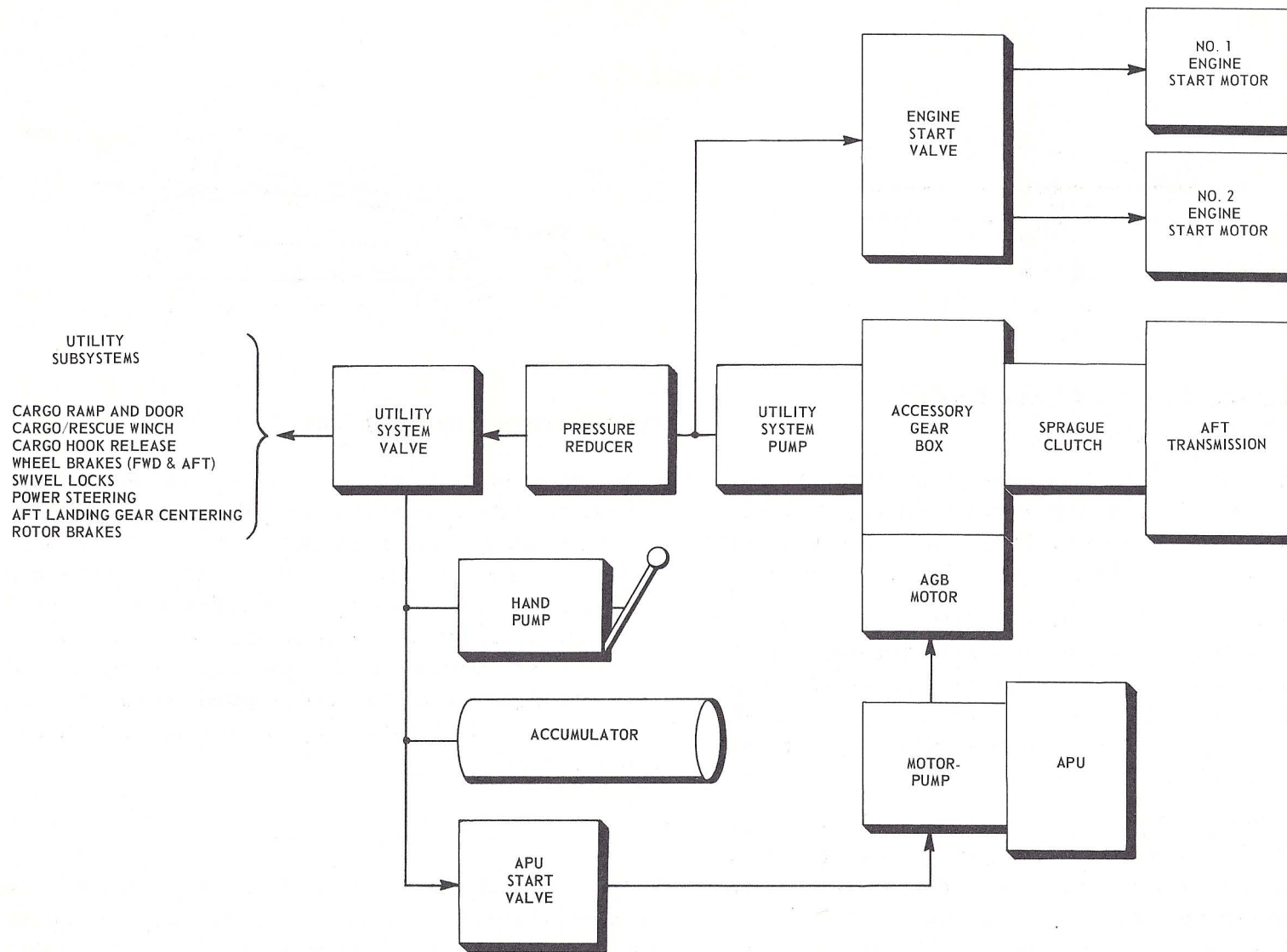

UTILITY HYDRAULIC SYSTEM



UTILITY HYDRAULIC SYSTEM

The utility hydraulic system consists of an engine starting and hydraulic power system and subsystems. The subsystems consist of a ramp actuating system, a wheel brake system, a cargo/rescue winch, a cargo hook release system, and a power steering system. The engine starting and hydraulic power system supplies hydraulic fluid at 4000 psi for engine starting and at 3000 psi for the subsystems.

An accessory gear box, driven by the aft

transmission, drives the utility hydraulic system pump to pressurize the system. A 1-way drive, overrunning (sprag-type) clutch, installed in the aft transmission, permits independent operation of the accessory gear box if the aft transmission is not operating. The auxiliary power unit (APU) can be used to supply power to drive the accessories. An APU-driven motor-pump supplies hydraulic pressure to drive a motor on the accessory gear box which, in turn, rotates the accessory drives.

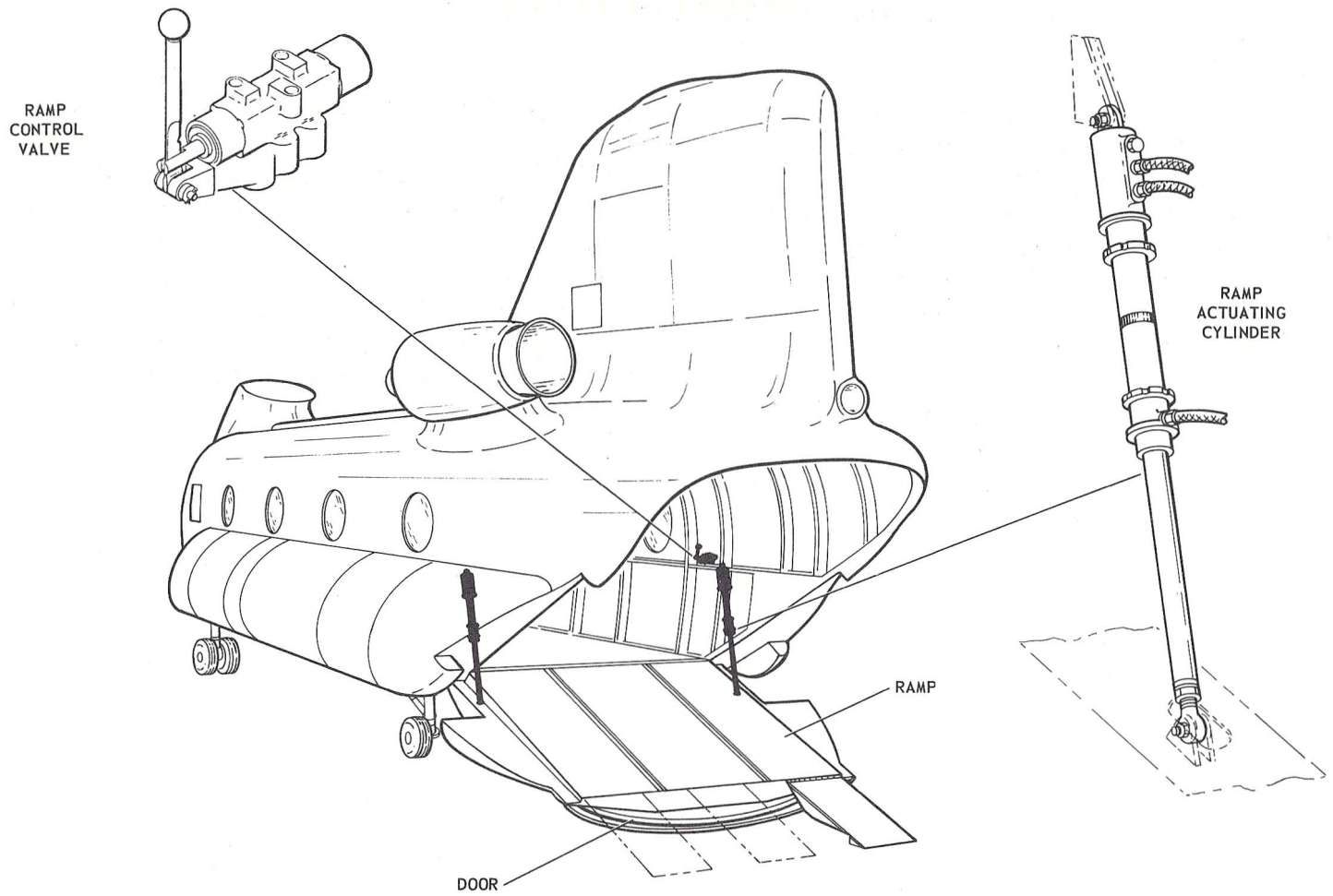

CARGO RAMP AND DOOR



UTILITY HYDRAULIC SUBSYSTEMS

The cargo ramp is operated hydraulically. The ramp can be stopped and held at any intermediate position. A retractable door is an integral part of the ramp. When the ramp is being lowered, a sequence valve causes the door to retract into the ramp automatically. When the ramp is being raised, the valve causes the door to extend. A manually controlled locking pin on the sequence valve permits the ramp to be raised and lowered with the door fully retracted. The ramp can also be operated when normal system pressure is not available by pressurizing the system accumulator with the hand pump.

The forward and aft wheel brakes are operated simultaneously when the aft landing gear is centered, swivel locks engaged, and the brake pedals depressed. The forward wheel brakes are operated independently when the aft landing gear is not centered and locked.

Aft landing gear centering is accomplished hydraulically when swivels are locked. Park

brakes are applied to the forward wheels and to the aft wheels when the above conditions are met. The pilot and copilot master cylinders are isolated from each other by brake transfer valves.

The cargo/rescue winch is a hydraulically driven, level winding reel with an automatic brake. The brake is released hydraulically when winch operation is selected. Winch speed and direction is controlled by a proportional solenoid valve and rheostats at the pilot's control panel and hoist operator's position. Maximum "reel-out" speed is limited by flow-regulation.

The external cargo hook is normally released hydraulically and reengaged pneumatically. If utility hydraulic pressure should fail, the hook can be released pneumatically. An emergency "manual" release is also provided on the cargo hook assembly.

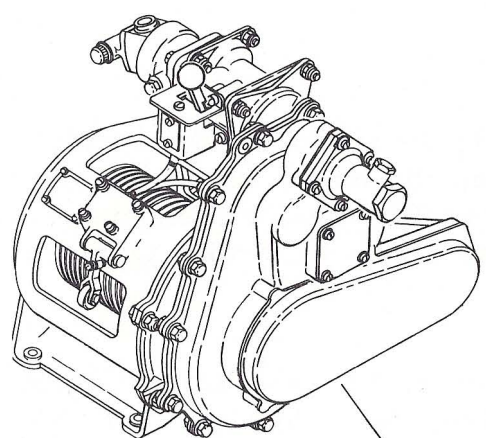

WINCH

WINCH CONTROL GRIP

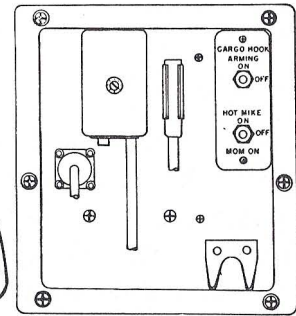
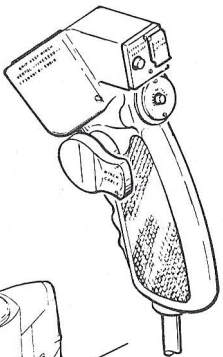

HOIST CONTROL PANEL

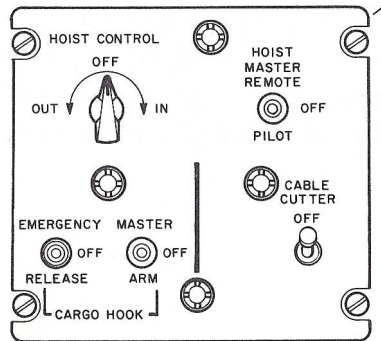
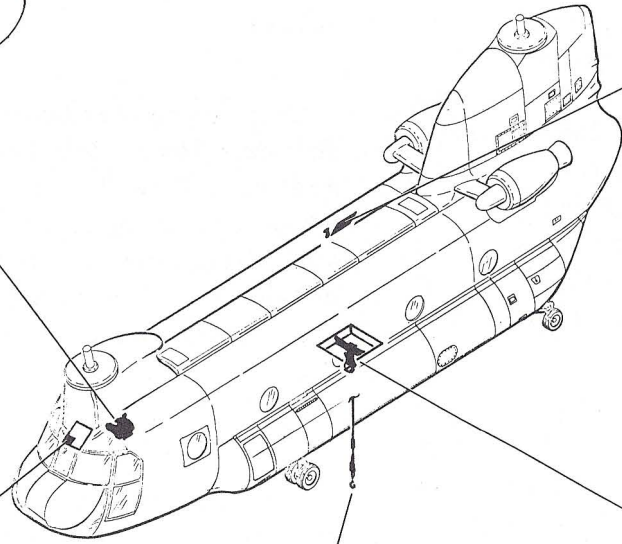

HOIST CONTROL PANEL

CABLE HOOK AND QUICK DISCONNECT



EMERGENCY RELEASE (MANUAL)

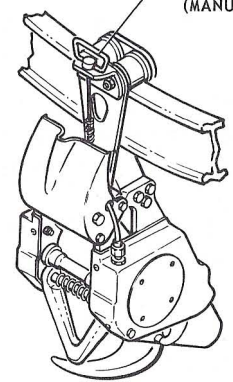

CARGO HOOK

CARGO HOIST SYSTEM

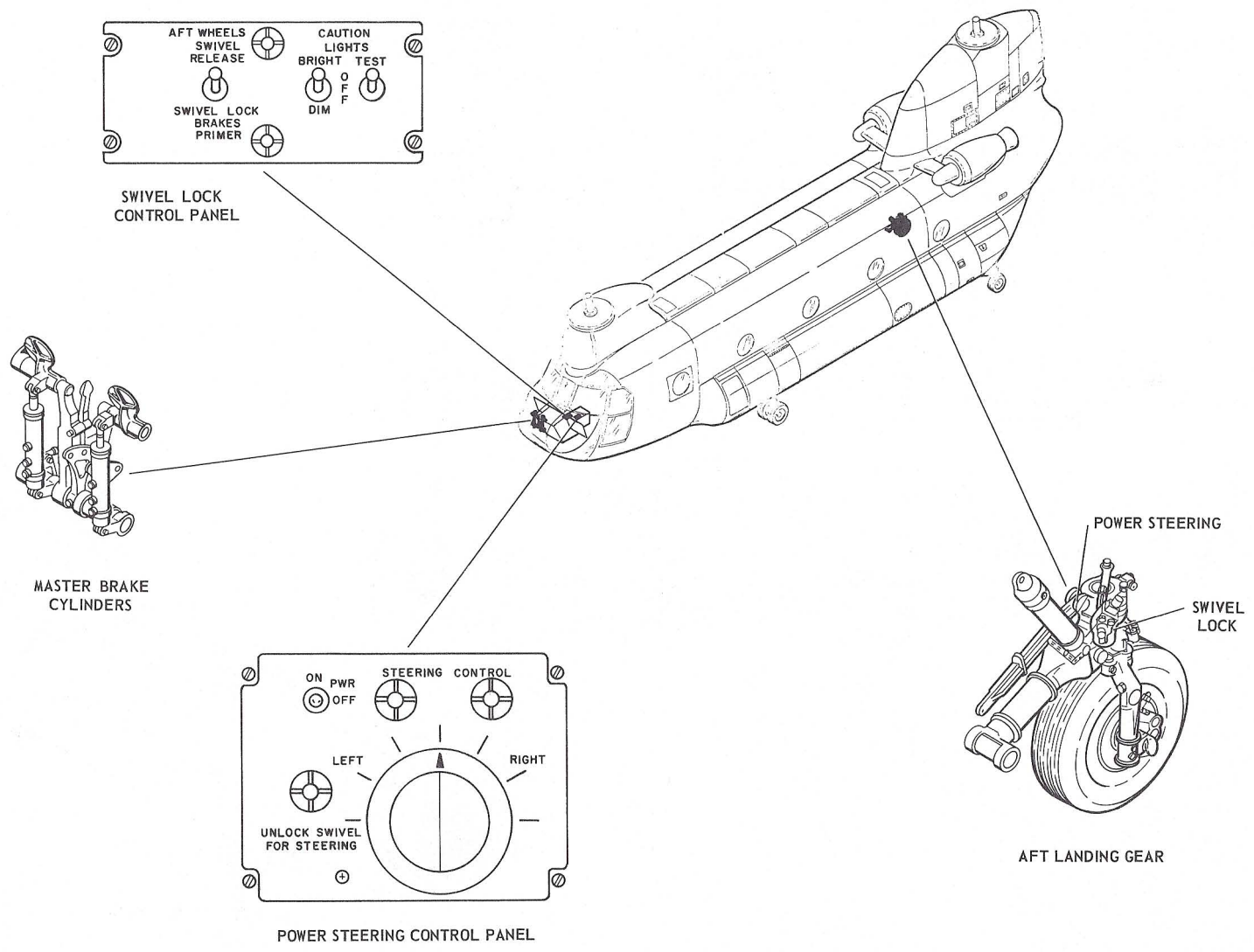

SWIVEL LOCK, POWER STEERING AND WHEEL BRAKES

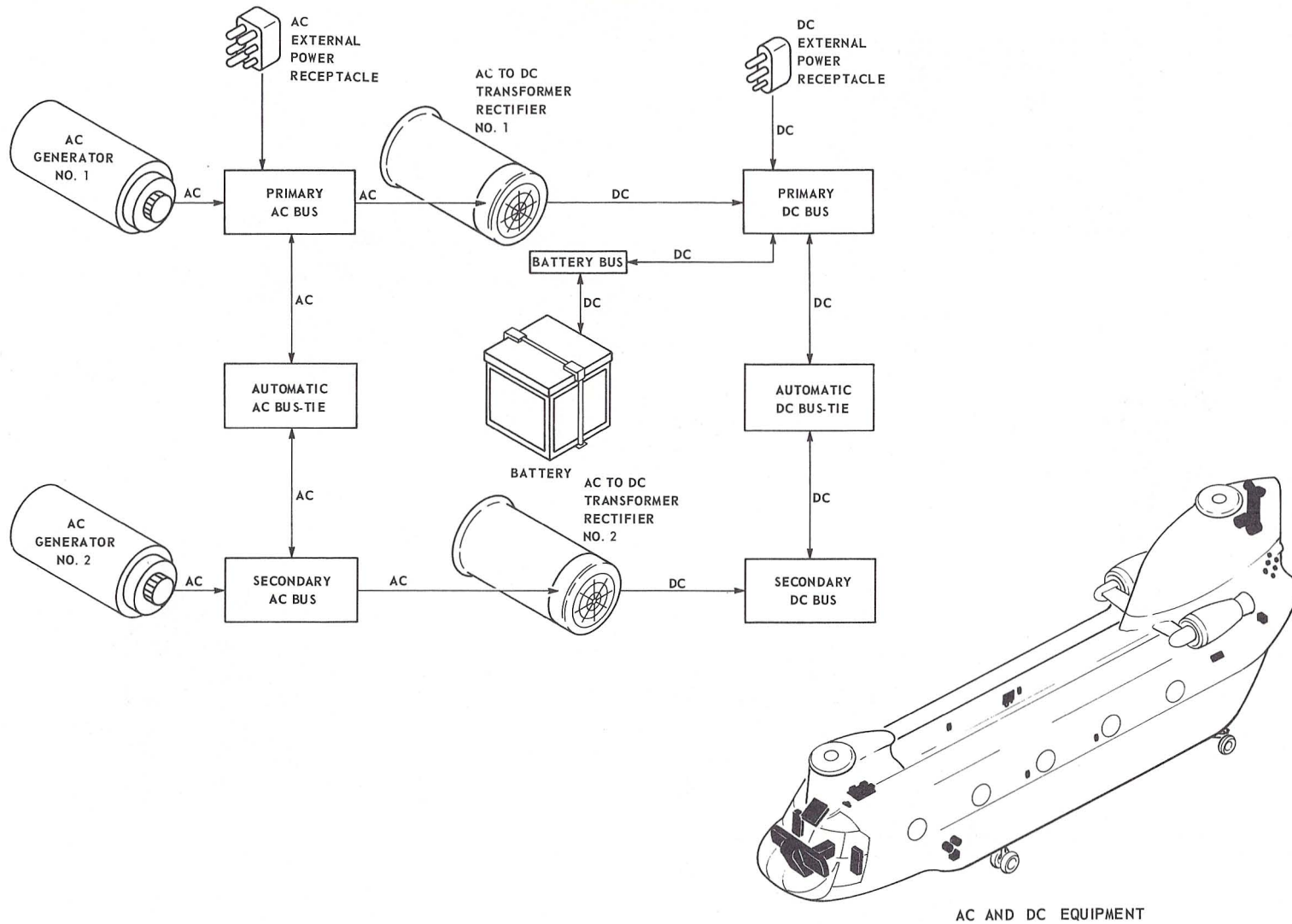

AC AND DC ELECTRICAL SYSTEM



AC-DC ELECTRICAL SYSTEMS

The primary source of electric power for this helicopter is an ac generating system. Two ac generators (alternators) are driven by the accessory gear box on the aft transmission. Each produces 120/208-volt, 3-phase, 400-cycle current; one (No. 1) generator supplies power to primary buses and the other (No. 2) generator supplies power to secondary buses. An auxiliary bus is connected to the primary bus through a bus-tie relay. The primary and secondary buses are separated electrically by the open contacts of another bus-tie relay; if either generator fails, this relay closes automatically to connect both the primary and secondary buses to the operating generator to ensure continuous operation of all ac equipment. A caution light warns the pilot whenever a generator becomes inoperative.

The ac system is protected from overvoltage, undervoltage, and underfrequency conditions by a generator protection panel. During engine starting, the No. 2 generator is disconnected automatically to reduce the starting load on the auxiliary power unit. Two ac loadmeters located on the center section of the instrument panel indicates generator output relative to the rated load.

Two transformer-rectifiers located in the forward section of the left-hand pod supply 28-volt dc. Direct current is also supplied by a 24-volt nickel-cadmium battery. Dc power is supplied from one (No. 1) transformer-rectifier to a primary bus and from the other (No. 2) transformer-rectifier to a secondary bus. A bus-tie relay is located between the primary and secondary buses. If either transformer-rectifier fails, the relay closes to connect the two buses; this ensures continuous operation of all dc equipment. In addition, a radio bus and an emergency bus are connected to the primary bus thru a bus-tie relay and an emergency bus relay, respectively. The emergency bus can be connected directly to the battery through the emergency bus relay. A caution light on the console warns the pilot if a transformer-rectifier becomes inoperative.

Both ac and dc can be supplied to the helicopter through external power receptacles. If only ac external power is utilized, dc power is supplied by the helicopter transformer-rectifiers. If both ac and dc external power is used, the transformer-rectifiers are automatically disconnected from the circuit. If only dc external power is available, the installed apu must be operated to obtain ac power.

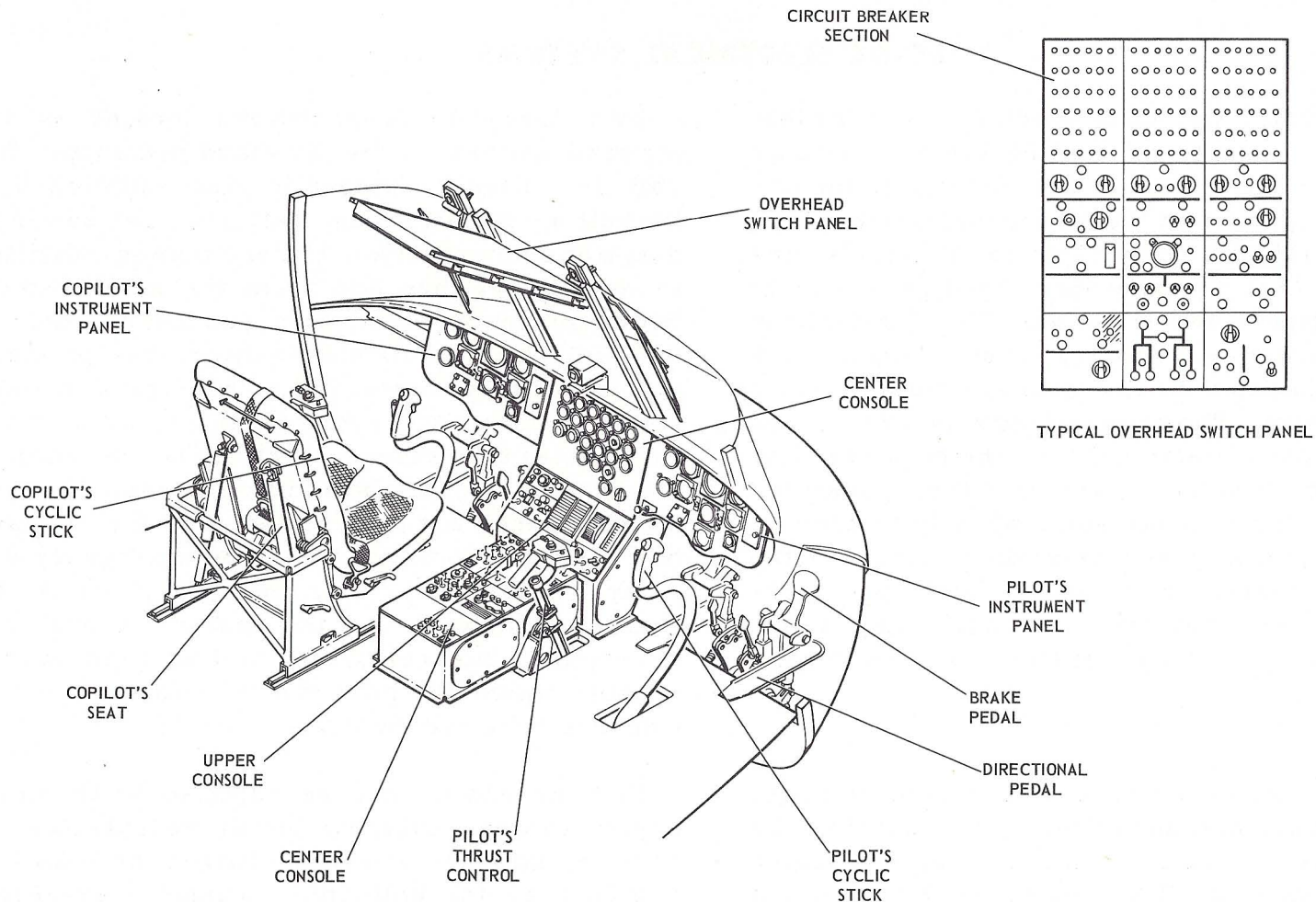

TYPICAL COCKPIT



COCKPIT ARRANGEMENT

Basic helicopter missions, operational commitments and varied subsystem installations may alter the specific combinations of cockpit equipment. However, a typical arrangement of systems controls plus standard flight and non-flight instrumentations will be found in most CH-47 helicopters.

A three-section instrument panel is located on the forward end of the console. The center section contains engine, transmission, fuel, hydraulic, electrical and cyclic trim instruments which are shared by both the pilot and the copilot. The engine fire warning lights and fire control handles are located at the top of this section. The pilot section (right) and copilot section (left) contain dual indicators for rotor rpm, engine torque, airspeed, altitude, attitude, vertical velocity, heading, and other navigation.

There are three single installation control panels which are shared by both pilots: the upper console, the lower console and the overhead control panel. The overhead control panel contains a circuit breaker section in addition to electrical controls for lighting, heating, hoist and hook, APU, engine fuel, electrical and hydraulic systems.

Subsystem caution lights, the cyclic stick control and navigational equipment controls are mounted on the upper console.

The lower console is situated between the pilots' seats and contains controls for engine condition, cyclic trim, power steering SAS and swivel locks. The major portion of the console is occupied by communication and navigation equipment which includes interphone, FM liaison, AF, VHF and UHF radio, emergency VHF transmitter, direction finding, range bearing and identification.

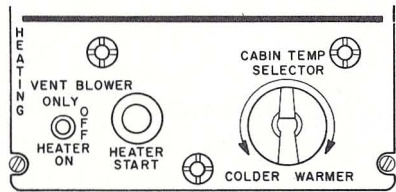

HEATER CONTROL PANEL

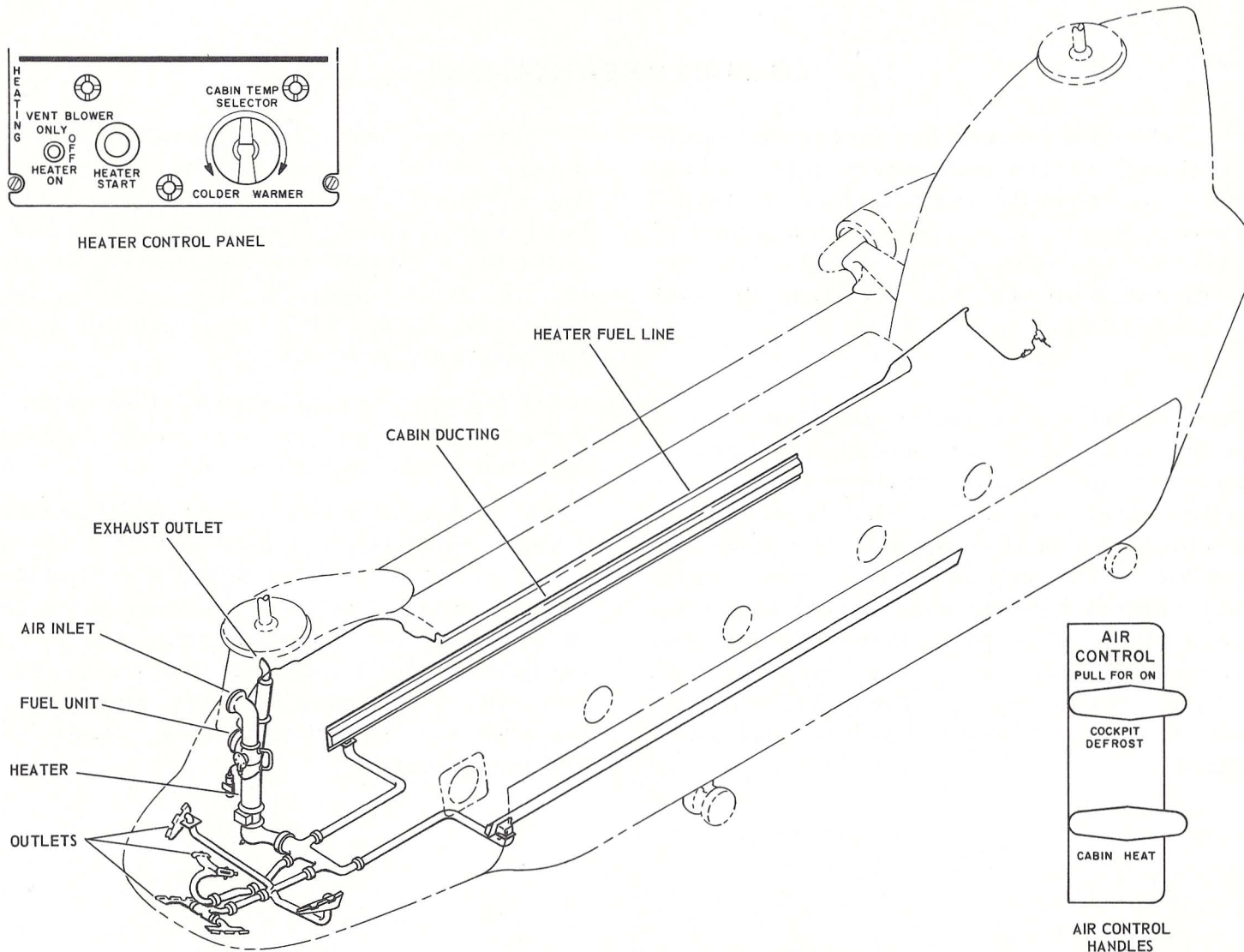

HEATING AND VENTILATING SYSTEM



HEATING AND VENTILATION SYSTEM

The helicopter's heating and ventilating system provides either heated or unheated ventilating air to the cabin and cockpit areas. The system includes a 200,000 BTU/hr-capacity combustion-type heater, a blower, ducting, and control and regulating equipment. Fuel to operate the heater is obtained from the left-hand fuel tank.

The heater and the blower are mounted vertically on the right-hand side of the helicopter directly aft of the cockpit bulkhead. The heater consists of an outer tube and jacket assembly in which an inner combustion tube is positioned concentrically.

To provide the system's air supply, the blower draws air from a screened opening located on the forward upper cabin section. The air is forced through the heater where it is channeled into ventilating- and combustion-type air. A vaporized fuel-air mixture is ignited and burned in the combustion tube. Ventilating air passes over the heated combustion tube and, in turn, becomes heated. It then enters the ducting network. Combustion gasses are discharged through an exhaust outlet.

When the system is used entirely for ventilating, combustion does not occur. In this case, outside air is forced through the system along the same route.

During the heating operation, a protective system is provided by four switches. Three thermal switches are used for overtemperature protection and a cycling function; a differential pressure switch is used to stop heater operation if there is insufficient air for the heater to function properly.

The cabin temperature is automatically controlled by the mode selecting switch and the heater start switch, located on the overhead switch panel in the cockpit, the temperature controller in the heater compartment, the temperature selector on the overhead switch panel, and the cabin thermostat on the left-hand side of the cockpit entranceway.

Control handles, located in the cockpit, permit the selection of airflow routing and defogging or defrosting of the cockpit enclosure. Fourteen manually adjustable outlets are provided in the cabin fuselage section.

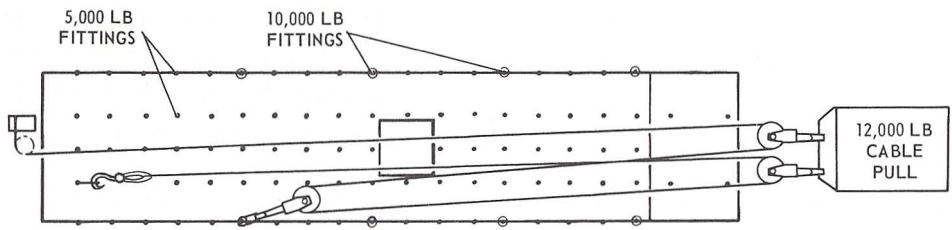
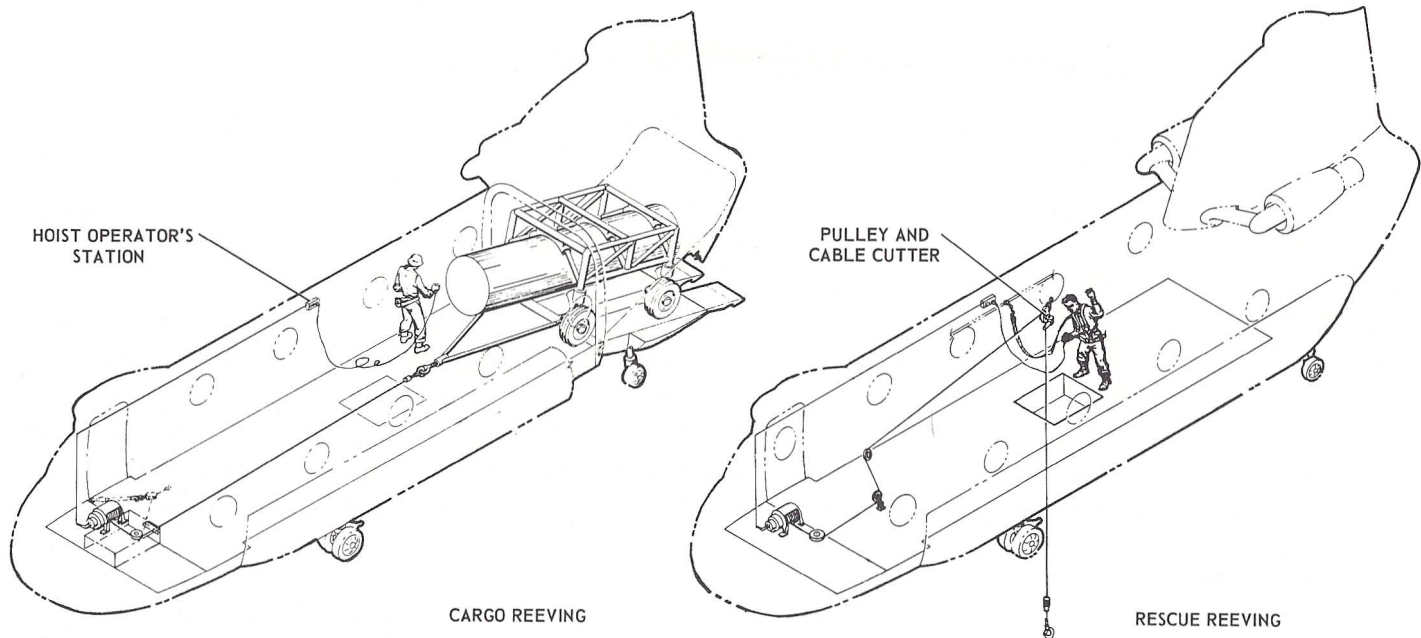

TIEDOWN FITTINGS AND PULLEY ARRANGEMENT

CARGO/RESCUE OPERATION



CARGO/RESCUE

The primary part of this system is the hydraulically operated winch, controlled by either a crewman in the cabin or the pilot. The winch utilizes a 2-speed gear train to provide a slow retrieval rate for cargo handling and a more rapid rate for rescue operations. An overload device automatically stops the winch before a snagged lead can break the cable.

Pulley blocks are provided which can be attached to the cargo tiedowns to reeve the cable over the floor at any desired lateral location, for winching cargo into or out of the aircraft through the ramp and the door.

For rescue operations, the cable is reeved upward at station 120.00, along the overhead to the rescue hatch, and then down through the hatch. The pulley block directly over the hatch is equipped with an explosive cartridge-actuated cable cutter for emergency use.

A limit switch interconnected to the operator's station controls plug stops the winch when the hook nears the ceiling pulley. Controls for the winch and the cable cutter are located in the cockpit and at the hatch.

The main cabin floor is designed for a distributed cargo load of 300 pounds per square foot and a concentrated load of 1,000 pounds per wheel in the center section. The outboard portion of the floor, or the treadway, is designed for a 2,500-pound wheel load. Vehicles can easily be driven in and out of the helicopter within these designated areas.

The floor contains eighty-seven 5,000-pound tiedown fittings and eight 10,000-pound fittings. There are also four 5,000-pound fittings on the loading ramp.

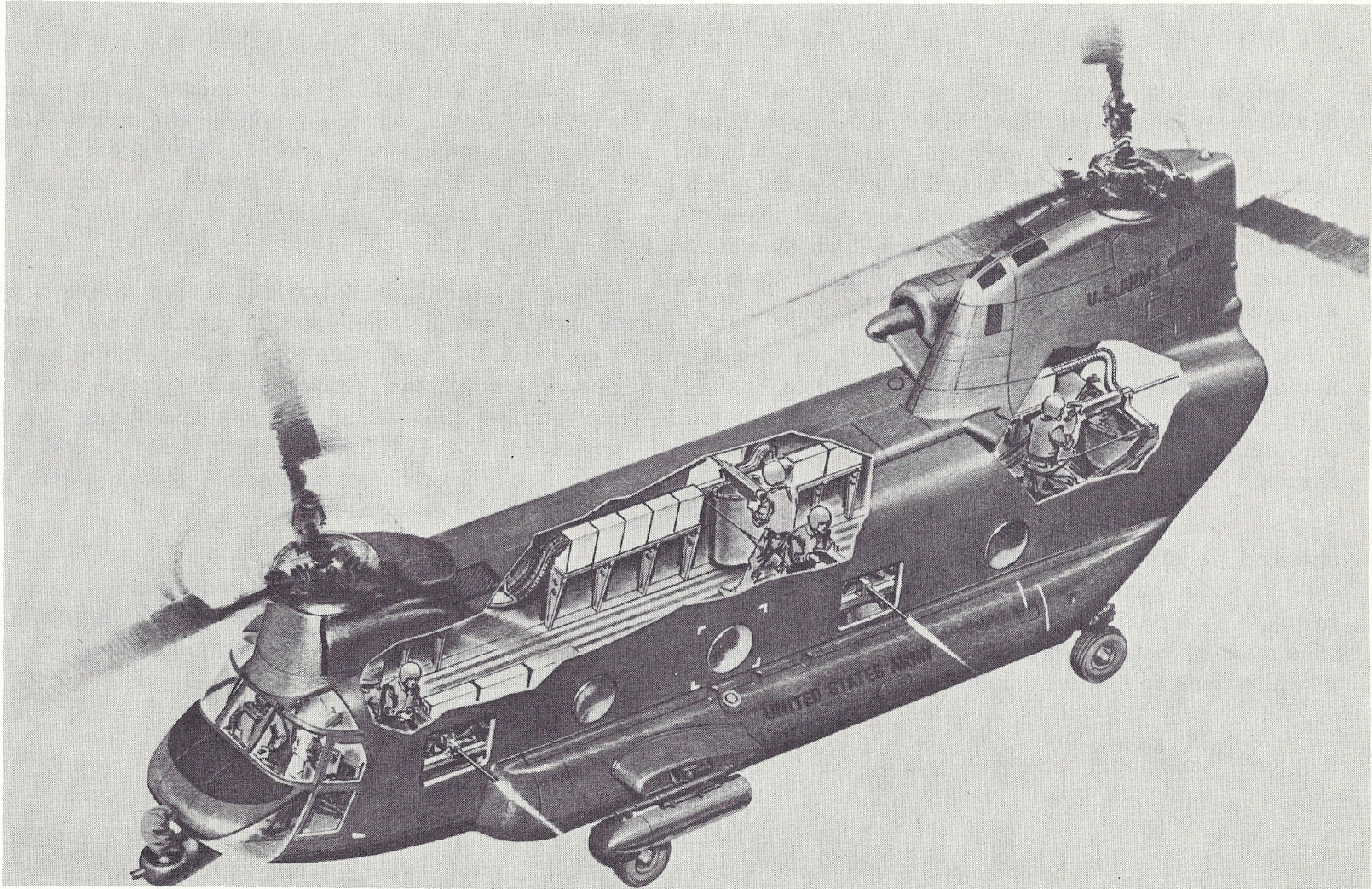



ARMED CH-47

Several CH-47 helicopters have been modified to provide fire support capability. The mission role of the "Armed Chinook" is to neutralize enemy ground fire in a landing assault area prior to the arrival of transport troop carriers. The armed versions of the CH-47 consist of a standard aircraft with vital system dualization, over a ton of installed armor and extensive array of weapons systems.

Certain items not required for fire support missions have been removed, including the auxiliary loading ramps, cargo door, heater, sound proofing, winch, hook and all but five 1-man troop seats.

Modifications include the addition of a combat interphone system, fuel fire suppression provisions, two crossfeed fuel shutoff valves and ballistic armor plating of the pilot's seat and vital areas of the flight controls and drive systems to withstand .50 caliber ammunition, pro-

viding a high degree of survivability for the aircraft.

Selection of weapons systems is based on range, fragmentation and rate-of-fire. Several cockpit operated weapons which may be installed include an M-5 40mm Grenade Launcher located in a rotating nose pod, XM-18 7.62mm Machine Gun Pods, XM-159 2.75-inch Rocket Launcher Pods or M-24 A1 20mm Automatic Guns, any of which are located on weapons pylons on either side of the aircraft.

The flanks of the aircraft are protected by four gunners stationed in two windows on each side of the cabin area. Each gunner is equipped with either an AM-M2 .50 caliber or KM-60D 7.62mm Machine Gun on a flexible mount. Another gunner with a similar weapon is stationed aft on the rear loading ramp to protect the aircraft during departure from the assault area. The "Armed Chinook" carries more than a ton of expendable munitions.

